



SCRRA Excavation Support Guidelines



July 2009



TABLE OF CONTENTS

1.0	FORWARD	1
1.1	PURPOSE	1
1.2	LIMITATIONS AND DISCLAIMERS	1
1.3	CHANGES, UPDATES AND EFFECTIVE DATE	2
1.4	REFERENCES	2
1.5	DEFINITIONS	3
1.6	ACRONYMS	7
2.0	BASIC EXCAVATION REQUIREMENTS	8
2.1	RAILROAD ZONE OF INFLUENCE	8
2.2	VARIANCES	11
2.3	EXCEPTIONS FOR MINOR CONSTRUCTION	11
2.4	RIGHT-OF-ENTRY AGREEMENTS	12
2.5	RIGHT-OF-WAY	12
2.6	UTILITIES	13
2.7	SAFETY REGULATIONS	13
2.8	CONSTRUCTION	13
2.9	CONTRACTOR OPERATING RESTRICTIONS	14
2.10	PROTECTIVE DIVIDERS	15
2.11	HANDRAILS AND WALKWAYS	15
2.12	CLEARANCES	15
2.13	SHORING REMOVAL	15
3.0	TEMPORARY SHORING SYSTEMS	17
3.1	OWNER-DESIGNED TEMPORARY SHORING REQUIREMENT	17
3.2	PREFERRED SHORING TYPES AND ELEMENTS	17
3.3	PROHIBITED SHORING TYPES AND ELEMENTS	18
4.0	LOADING ON TEMPORARY SHORING SYSTEMS	19
4.1	GENERAL	19
4.2	SOIL LOADS	19
4.2.1	Soil Types and the Determination of Soil Properties	19
4.2.2	Loading from Retained Soil on Flexible Systems	19



4.2.3	Loading from Retained Soil on Restrained Systems.....	21
4.2.4	Passive Resistance.....	21
4.3	GROUNDWATER LOAD	22
4.4	SURCHARGE LOADS.....	22
4.5	EARTHQUAKE (SEISMIC) LOAD.....	22
4.6	COMBINATION OF LOADS AND LOADING CASES	22
5.0	RAILROAD LIVE LOAD SURCHARGE.....	24
5.1	GENERAL	24
5.2	SURCHARGE FROM MULTIPLE TRACKS	24
5.3	SIMPLIFIED SURCHARGE PRESSURE DISTRIBUTION	24
5.4	APPLICATION OF SURCHARGE PRESSURES	26
5.5	SURCHARGE FOR PERPENDICULAR SHORING WALLS.....	26
5.6	COMBINATION WITH SURCHARGE FROM OTHER SOURCES	26
6.0	SHORING ANALYSIS METHODOLOGIES	30
6.1	CONTINUOUS SHORING WALLS	30
6.2	SOLDIER PILE SHORING WALLS	30
6.3	ANALYSIS OF CANTILEVER WALLS	31
6.4	ANALYSIS OF WALLS WITH A SINGLE LEVEL OF BRACING	31
6.4.1	Free Earth Support Method.....	31
6.4.2	Fixed Earth Support Method	32
6.4.3	Factor of Safety for Shoring Wall Embedment Depth	32
6.5	ANALYSIS OF WALLS WITH MULTIPLE LEVELS OF BRACING	32
6.5.1	Embedment Depth	32
6.5.2	Analysis of Shoring Wall.....	33
6.5.3	Determination of Bracing Loads	33
6.6	ANALYSIS OF BRACING SYSTEMS.....	33
6.7	LAGGING ANALYSIS.....	34
6.8	GENERAL SHORING REQUIREMENTS.....	34
6.8.1	Minimum Embedment Depth.....	34
6.8.2	Secondary Bracing.....	34
6.8.3	Connections.....	34
6.8.4	Stiffeners.....	35
6.9	SHORING DEFLECTION AND SETTLEMENT	35
7.0	MATERIAL PROPERTIES AND ALLOWABLE STRESSES.....	36
7.1	STEEL.....	36
7.1.1	Structural Steel	36
7.1.2	Steel Sheet Piling.....	36



7.1.3	Prestress Strand or Rod.....	36
7.1.4	Wire Rope Cable.....	37
7.2	CONCRETE	37
7.3	WOOD.....	37
7.4	OTHER MATERIALS.....	37
8.0	SPECIAL CONDITIONS	38
8.1	SEALED SHORING.....	38
8.2	DEWATERING	38
8.3	BOTTOM STABILITY.....	39
8.3.1	Piping.....	39
8.3.2	Bottom Heave	39
8.4	GLOBAL STABILITY.....	40
8.5	TIEBACKS.....	40
8.6	DEADMEN	40
9.0	TRACK MONITORING	42
9.1	PURPOSE.....	42
9.2	LIMITATION ON TRACK MOVEMENT	42
9.3	MINIMUM MONITORING REQUIREMENTS	42
9.4	SUPPLEMENTAL MONITORING	43
9.5	SPECIAL MONITORING	46
9.6	ACCESS AND FLAGGING	46
10.0	SUBMITTAL REQUIREMENTS.....	47
10.1	GENERAL	47
10.2	EXCLUSIVE TRACK WINDOWS.....	47
10.3	EXCEPTIONS, WAIVERS AND VARIANCES.....	48
10.4	DRAWINGS.....	49
10.5	DESIGN CALCULATIONS.....	50
10.6	DESIGN CHECKLIST	50
10.7	OTHER INFORMATION	50
10.8	SITE SPECIFIC WORK PLAN (SSWP).....	50
10.9	CONSTRUCTION VERIFICATION	52



LIST OF FIGURES

Figure 2.1: Railroad Zone of Influence	10
Figure 4-1: Construction of an Apparent Pressure Diagram	20
Figure 5-1: E-80 Railroad Live Load Surcharge Using the Boussinesq Equation	25
Figure 9-1: Minimum Monitoring Requirements	443
Figure 9-2: Method of Loaded Measurement	44
Figure 9-3: Reporting Static Top of Rail Survey Results	45
Figure 9-4: Reporting Loaded Measurement Results	45

LIST OF TABLES

Table 5.1: Railroad (E-80) Live Load Lateral Surcharges	27
---	----



LIST OF APPENDICES

APPENDIX A – SUBMITTAL CHECKLISTS.....	54
DESIGN CHECKLIST	545
REVIEW CHECKLIST	547
APPENDIX B – SAMPLE CALCULATIONS	59
EXAMPLE 4.1 – DEVELOP AN ACTIVE SOIL PRESSURE DIAGRAM	60
EXAMPLE 4.2 – DEVELOP AN APPARENT PRESSURE DIAGRAM	61
EXAMPLE 4.3 – DETERMINE PASSIVE RESISTANCE (COHESIONLESS SOIL)	62
EXAMPLE 4.4 – DETERMINE PASSIVE RESISTANCE (COHESIVE SOIL)	63
EXAMPLE 5.1 – RAILROAD LIVE LOAD SURCHARGE FROM TWO TRACKS	64
EXAMPLE 5.2 – RAILROAD LIVE LOAD SURCHARGE FROM THREE TRACKS	66
EXAMPLE 5.3 – “SIMPLIFIED” RAILROAD LIVE LOAD SURCHARGE	68
EXAMPLE 6.1 – CANTILEVER SOLDIER PILE AND LAGGING SHORING WALL	69
EXAMPLE 6.2 – SHEET PILE SHORING WALL WITH ONE LEVEL OF BRACING (FREE EARTH SUPPORT METHOD)	73
EXAMPLE 6.3 – SHEET PILE SHORING WALL WITH ONE LEVEL OF BRACING (FIXED EARTH SUPPORT METHOD)	77
EXAMPLE 6.4 – ANALYSIS OF A DIAPHRAGM SHORING WALL WITH THREE LEVELS OF BRACING	80
EXAMPLE 7.1 – WIDE FLANGE WALE DESIGN	86
EXAMPLE 7.2 – PIPE STRUT DESIGN	88
EXAMPLE 7.3 – SHORING WALL DESIGN.....	89
EXAMPLE 7.4 – WOOD LAGGING DESIGN	90
APPENDIX C – SCRRRA DESIGN EXCEPTION FORM.....	92



1.0 Forward

1.1 PURPOSE

These Excavation Support Guidelines provide the minimum requirements for excavations and temporary excavation support adjacent to the Southern California Regional Rail Authority (SCRRA) railroad tracks. The design of permanent retaining walls and other systems of permanent earth retention adjacent to SCRRA tracks is addressed in the SCRRA Design Criteria Manual and other applicable guidelines.

SCRRA has developed the criteria and requirements specified herein for the protection of their rail facilities and operating system when construction and excavation activities occur adjacent to active railroad tracks. Given the risks associated with construction and excavation adjacent to an active railroad commuter/passenger and freight line, the design requirements and construction limitations specified herein are conservative and may be more restrictive than those commonly required by other agencies, for example, excavations adjacent to a highway. Specialized requirements and recommended design practices for excavation and excavation support contained in these Guidelines are intended to improve safety of excavation adjacent to active railroad tracks for railroad operations, the traveling public and Contractor personnel and reduce delays and impacts to railroad operations.

The design, submittal and review process defined in these Guidelines shall be adhered to for all excavations on SCRRA Right-of-Way or excavation activities that might affect operations on SCRRA railroad tracks, signals and other related facilities. Deviations or variances from the provisions of these Guidelines shall be presented to SCRRA for review following the process given in Section 10.3.

1.2 LIMITATIONS AND DISCLAIMERS

These Guidelines are not intended for use as a textbook, and shall not be used as a substitute for engineering knowledge, experience, or judgment. The criteria, information and analysis methodologies presented in these Guidelines have been developed in accordance with recognized engineering principles and in accordance with railroad industry practice. SCRRA does not warrant the accuracy or completeness of these Guidelines, nor that are the Guidelines free from errors and omissions. Users of these Guidelines shall independently validate and verify the information contained herein and should promptly notify SCRRA of any discrepancies or inconsistencies discovered in the course of utilizing these Guidelines.

Design of temporary shoring systems for excavation support shall be prepared by a licensed California professional engineer who shall be solely responsible for verifying the accuracy, suitability and applicability of the information contained in these Guidelines for any specific project.

Review and acceptance of submittals by SCRRA shall not relieve the Contractor and Engineer in Responsible Charge of responsibility for the design and construction of the temporary shoring system, including responsibility for errors and omissions in submittals, and construction deviations from accepted design plans. Excavation safety shall be the responsibility of the Contractor performing the excavation and the Engineer in Responsible Charge who designed the shoring for the excavation.



1.3 CHANGES, UPDATES AND EFFECTIVE DATE

These Guidelines as well as the referenced SCRRRA Documents listed in Section 1.4 are available on the SCRRRA web site: www.metrolinktrains.com. The most recent date shown in the lower right hand footer of each page is the effective date of the Guidelines. The most recent effective date shall supersede all previous versions. Revisions and updates to the Guidelines will be posted on the web site. Users of these Guidelines shall be solely responsible for checking the web site for updates and utilizing the latest version. Forward any proposed changes or updates to these Guidelines to the SCRRRA Director of Engineering and Construction for consideration. **The current effective date of these Guidelines shall be July 2009.**

1.4 REFERENCES

The following documents are referenced in these Guidelines:

- Southern California Regional Rail Authority (SCRRRA) Documents, latest edition:
 - Design Criteria Manual
 - Track Standards
 - SCRRRA Standard Specifications
 - Track Maintenance, Right of Way and Structures, Engineering Instructions
 - Roadway Worker On-Track Safety Instructions
 - Form 4, Agreement for Moving Oversized Loads Over Highway-rail grade Crossings
 - Form 5, Indemnification and Assumption of Liability Agreement
 - Form 6, Temporary Right-of-Entry Agreement
 - Form 36, Right-of-Way Encroachment Approval Procedures
 - Form 37, Rules and Requirements for Construction on Railroad Property
 - General Safety Regulations for Third Party Construction and Maintenance Activity on SCRRRA Member Agency Property
 - General Code of Operating Rules
- American Railway Engineering and Maintenance-of-Way Association (AREMA), Manual for Railway Engineering, latest edition.
- State of California Department of Transportation (Caltrans), Trenching and Shoring Manual, latest edition.
- Federal Railroad Administration (FRA), Safety Regulations, 49 CFR Part 214, latest revision.
- California Occupational Safety and Health Administration (Cal/OSHA), California Code of Regulations, Title 8, Chapter 4, Division of Industrial Safety, Subchapter 4, Construction Safety Orders, latest revision.
- California Public Utilities Commission (CPUC), General Orders, latest revision.
- American Institute of Steel Construction (AISC), Steel Construction Manual - Allowable Stress Design (ASD), thirteenth edition, 2005.



- American Concrete Institute (ACI), Building Code Requirements for Structural Concrete (ACI 318), latest edition.
- American Welding Society (AWS), D1.1, Structural Welding Code – Steel, latest edition.
- Post-Tensioning Institute (PTI), Recommendations for Prestressed Rock and Soil Anchors, 2004.
- Federal Highway Administration (FHWA), Geotechnical Engineering Circular No. 4, Ground Anchors and Anchored Systems, FHWA-IF-99-015, June 1999.
- Federal Highway Administration (FHWA), Geotechnical Engineering Circular No. 7, Soil Nail Walls, FHWA-IF-03-017, March 2003.

1.5 DEFINITIONS

A. Railroad Terminology

Basic Safety Envelope

The area within 25 feet horizontally of the centerline of the nearest active track. The pair of imaginary lines, which define the outside boundaries of the Basic Safety Envelope, extend vertically up and down infinitely. For the purpose of these Guidelines, all construction activities within these boundaries will be considered to have the potential to foul the track and will be constrained as necessary by the SCRRRA Employee-in-Charge/Flagman.

Contractor

The individual, firm, partnership, corporation, joint venture or combination thereof that has entered into a construction contract with the legal entity for which the work is being performed. For purpose of these Guidelines, Contractor also includes any sub-contractor, supplier, agent or other individual entering the SCRRRA Right-of-Way during performance of the work.

Cross Level

The difference in elevation between the tops of both rails measured along a line perpendicular to the track centerline.

Engineer in Responsible Charge

The licensed professional engineer in responsible charge of shoring system design, whose seal and signature shall be affixed to the drawings, specifications, calculations, and other documents used in the design and construction of excavation support. For the purpose of these Guidelines, the Engineer in Responsible Charge also includes other people designated by the licensed professional engineer in responsible charge and working at his/her direction.



Guidelines	For the purpose of this document, Guidelines shall be considered this document (SCRRA Excavation Support Guidelines) in part or in its entirety. Other documents may be referred to as guidelines and shall not mean this document.
Member Agency	The county transportation agency whose property is directly affected by the project. The SCRRA Member Agencies include: the Los Angeles Metropolitan Transportation Authority (METRO), the Orange County Transportation Authority (OCTA), the Riverside County Transportation Commission (RCTC), the San Bernardino Associated Governments (SANBAG) and the Ventura County Transportation Commission (VCTC).
Operating System	Includes, but is not limited to, the tracks on which trains and “on-track” equipment operate or may potentially operate, and in addition any facilities closely related to the operation of the railroad system including signal and communications masts, bridges, poles, cables and houses, tunnels, culverts, bridges, access roads, highway-rail grade crossings and station platforms.
Public Agency	The federal government and any agencies, departments, or subdivisions thereof; the State of California; and any county, city, city and county district, public authority, joint powers agency, municipal corporation, or any other political subdivision or public corporation therein, responsible for sponsoring a project. This includes SCRRA Member Agencies.
Railroad Zone of Influence	The zone within which shored excavation is required and the shoring system is required to be designed for railroad live load surcharge. See Figure 2-1.
Right-of-Way	A strip of land, real estate or property of interest, under the ownership or operating jurisdiction of SCRRA or Member Agency on which railroad tracks, other structures and facilities are constructed.
SCRRA	Southern California Regional Rail Authority (aka Metrolink); A five-county joint powers authority, created pursuant to California Public Utilities Code Section 130255 and California Government Code Section 6500 et seq., to plan, design, construct, and then maintain and administer the operation of the regional passenger rail lines serving the counties of Los Angeles, Orange, Riverside, San Bernardino, and Ventura.
Shoofly	A temporary detour track to bypass an obstruction or construction site.
Site Specific Work Plan (SSWP)	A program, plan, and schedule prepared and submitted by the Contractor and accepted by SCRRA that accurately describes and illustrates the manner in which work within the Basic Safety Envelope will be accomplished, the potential impacts on elements of the Operating System and the manner and methods by which these elements will be protected from any potential impact, and/or the manner in which work will be accomplished within SCRRA allotted Work Windows.



Third Party	An individual, firm, partnership, or corporation, or combination thereof, private or public, participating, sponsoring, or affected by a project. Government agencies and utilities may be considered a Third Party.
Work Window	A period of time with a specific beginning and ending time and duration for which the track, signals, bridges and other Operating System elements within the Basic Safety Envelope are temporarily removed from service or modified in some other manner and train and other operations suspended or modified to allow construction or maintenance to occur. Written authority from SCRRA and an accepted Site Specific Work Plan (SSWP) are required before a Contractor is granted a Work Window. The Contractor's Work Window shall have specific geographic limits, which are defined in the accepted SSWP. Modifications or suspension of train and on-track equipment movements resulting from a Work Window involves written changes to SCRRA's Rules of Train and On-Track Equipment Operations, which are known as Track Bulletins.
Exclusive Track Window	An approved Work Window in which no train movements (except Contractor or SCRRA work trains or equipment under control of the Employee-in-Charge/Flagman, per the SSWP) will operate on any track within the window limits. The Contractor may dismantle, remove, reconstruct, or otherwise obstruct tracks within the limits of such a window. Tracks removed, reconstructed or otherwise obstructed within the limits of such a window must be returned to the same condition as they were before the work started at the end of the time limits granted. This Work may be protected by track out of service, track and time limits, or by "Form B" Track Bulletin.
B. Shoring Terminology	
Deadman	A buried or partially buried structure that is utilized as an anchorage for tension rods that restrain a shoring wall. Deadman anchorage may be provided by soldier piles, sheet piling, or concrete blocks or walls.
Deep Soil Mix Wall	An augered, cement grout soil improvement technique, incorporating soldier pile reinforcement, whereby in-situ soils are mixed in place with cement grout to form a row of overlapped soil-cement columns. These overlapped soil-cement columns are used for both groundwater cutoff and, with soldier piles, as a reinforced-soil diaphragm-type shoring wall.
Diaphragm Wall	A continuous shoring wall comprised of concrete or a mixture of cement and soil (usually with embedded vertical steel members) that is drilled or excavated in place prior to excavation in order to support lateral loads from retained soil and water. Examples of diaphragm walls include deep soil mix walls, secant walls, tangent walls, and slurry walls.
Grouting	Injection of fluid materials into the ground to improve the strength of ground, decrease permeability and prevent water inflows, and/or compensate for ground settlements and movements. Types of grouting



	include permeation grouting (cement, micro-cement, chemical, etc.), jet grouting, and compaction grouting.
Lagging	Timber boards, planking or sheathing, reinforced concrete planks, or steel plate secured between adjacent soldier piles.
Packing	Steel, wood, concrete or non-shrink grout used to fill gaps and transfer load between the shoring wall and bracing elements.
Preloading	Placement of initial loads in bracing members by jacking and shimming or wedging to assure adequate bearing of connected shoring elements and to reduce ground movements.
Secant Wall	A continuous shoring wall formed by a series of overlapped, concrete-filled drilled piers (otherwise commonly referred to as drilled shafts or cast-in-drilled-hole [CIDH] piles). A minimum of every other pier is reinforced to span vertically.
Sheet Piling	Vertical steel shapes that are driven into the ground and interlocked with each other to form a continuous wall in order to support lateral loads from retained soil and water.
Slurry Wall	Continuous, reinforced concrete wall constructed by filling a series of discrete trenches with tremie concrete. Tremie concrete displaces bentonite or polymer slurry that is in the trench. The slurry is used to prevent collapse of the trench during excavation for slurry wall placement. The resulting concrete barrier wall retains soil and groundwater on the exterior side of the slurry wall, and permits excavation and removal of soil on the interior side of the wall. Walls may be reinforced or non-reinforced.
Soil Nailing	A system in which soil nails are typically grouted, untensioned rebars that are installed in drilled holes in order to form a reinforced soil mass. Reinforced shotcrete is applied to the face of the excavation. Shotcreting and nail installation proceed in a top down manner as excavation proceeds.
Soldier Piles	Vertical steel shapes (typically wide flange or HP) installed to support lateral loads from retained soil (and water, if part of a sealed shoring system).
Strut	A brace (compression member) that resists thrust in the direction of its own length.
Tangent Wall	A shoring wall formed by a series of concrete-filled drilled piers (otherwise commonly referred to as drilled shafts or cast-in-drilled-hole [CIDH] piles) that are installed tangent to each other and do not overlap. A minimum of every other pier is reinforced to span vertically.



Tieback (Soil Anchor)	A tension element utilized to restrain a shoring wall. A tieback consists of a steel tendon (bar or strands) installed in a drilled hole. The tendon is bonded to the soil over its anchorage length with cement grout. The tendon is tensioned to provide positive restraint to the shoring wall and to reduce wall deflections.
Tremie Concrete	Concrete deposited under water or slurry by means of tremie equipment. The concrete displaces the water or slurry as the concrete is deposited.
Trench Shield or Trench Box	Pre-fabricated structure that is commonly installed to support lateral earth loads for utility installation, and whose walls commonly have no embedment into the soils below excavation subgrade. Trench shields are typically installed within pre-excavated slots and/or pushed into the ground as the excavation proceeds.
Wale	Horizontal beam used to brace vertical excavation shoring elements.

1.6 ACRONYMS

The following acronyms are used in this document:

AREMA	American Railway Engineering and Maintenance of Way Association
ASTM	American Society for Testing and Materials
BNSF	BNSF Railway Company
CADD	Computer-Aided Drafting and Design
Caltrans	California Department of Transportation
CFR	Code of Federal Regulations
CPUC	California Public Utilities Commission
FHWA	Federal Highway Administration
FRA	Federal Railroad Administration
METRO	Los Angeles County Metropolitan Transportation Authority
OCTA	Orange County Transportation Authority
OSHA	Occupational Safety and Health Administration
QA/QC	Quality Assurance / Quality Control
RCTC	Riverside County Transportation Commission
SANBAG	San Bernardino Associated Governments
SCRRA	Southern California Regional Rail Authority
SSWP	Site Specific Work Plan
UPRR	Union Pacific Railroad
VCTC	Ventura County Transportation Commission



2.0 Basic Excavation Requirements

Any proposed excavation that may occur in SCRRA Right-of-Way or that may affect operations on SCRRA tracks must adhere to the design, submittal and review requirements presented in these Guidelines and shall not proceed without acceptance by SCRRA.

2.1 RAILROAD ZONE OF INFLUENCE

The Railroad Zone of Influence is defined on Figure 2-1. The area below the Influence Line is divided into four zones. Requirements and limitations for excavation and temporary excavation support systems within each zone are described in detail below. Excavation requirements apply on or off of SCRRA Right-of-Way. Excavation beyond the Railroad Zone of Influence shall satisfy OSHA and other applicable requirements.



ZONE 1:

- **Excavation is prohibited.**
- Alternates to shored excavations shall be utilized. Potential alternates include temporary relocation of the tracks away from the area of excavation or completion of excavation and backfilling work during an Exclusive Track Window that has been planned and approved in advance by SCRRA. Requirements for requesting an Exclusive Track Window are provided in Section 10.2. Minimum requirements for excavation and backfill work within Zone 1 are provided in Section 2.2. Prior to beginning any shoring SCRRA will typically require that the track be removed and hot mix asphalt concrete (HMAC) sub-ballast layer be placed, 8 inches thick, 12 feet wide (centered on the track centerline) and extending 20 feet in each direction past the length of the shored excavation. SCRRA shoofly requirements are provided in the SCRRA Design Criteria Manual.



ZONE 2:

- **No excavation or temporary shoring installation will be allowed without the special written permission of SCRRA.** Requirements for requesting a variance are provided in Section 10.3. Additional requirements for excavation and shoring within Zone 2 are provided in Section 2.2.
- Alternates to shored excavations shall be utilized when practical.
- If SCRRA grants a variance to allow excavation, vertical excavation with continuous shoring walls is required. Shoring installation shall be complete prior to any excavation. Design of the shoring system shall include lateral surcharge due to railroad live load.
- Prior to beginning any shoring SCRRA will typically require that the track be removed and hot mix asphalt concrete (HMAC) sub-ballast layer be placed, 8 inches thick, 12 feet wide (centered on the track centerline) and extending 20 feet in each direction past the length of the shored excavation.
- Examples of continuous shoring wall types include interlocked sheet piling or diaphragm walls. Diaphragm wall types include deep soil mix walls, secant pile walls, tangent pile walls, and slurry walls. Soldier piles and lagging are not allowed if excavation is necessary to install lagging.



ZONE 3:

- **Excavation requires temporary shoring.** Excavations shall be vertical. Continuous shoring walls installed prior to any excavation are preferred. Maximum excavation lifts shall be limited to five (5) feet for each stage of excavation for soldier pile and lagging walls or any other type of shoring that requires excavation of an open soil face prior to installing continuous support elements.
- If the shored excavation is 15 feet or less from the centerline of the track, prior to beginning any shoring SCRRRA may require that the track be removed and hot mix asphalt concrete (HMAC) sub-ballast layer be placed, 8 inches thick, 12 feet wide (centered on the track centerline) and extending 20 feet in each direction past the length of the shored excavation.
- **Design of the shoring system shall include lateral surcharge due to railroad live load.**



ZONE 4:

- Excavation requires temporary shoring.
- Lateral surcharge due to railroad live load need not be considered in the shoring design.
- The excavation shall be provided with a shoring system that actively supports the sides of the excavation and prevents the excavation faces from unraveling or moving. Sloped excavations are not permitted.
- Hydraulic and mechanical trench shores with sheeting, trench shields, and timber shoring may be utilized. However, installation of the shoring system must be completed before movement of trains is allowed on the adjacent track. Work Windows within which the shoring system installation must be completed shall be coordinated with SCRRRA.

EXCAVATIONS BEYOND INFLUENCE LINE:

- Lateral surcharge due to railroad live load need not be considered in the shoring design.
- Shored vertical excavations are preferred. Sloped excavations are discouraged. SCRRRA may require slope stability analysis for sloped excavations.
- Excavation and temporary shoring shall comply with Cal/OSHA and other applicable requirements.

Excavations shall also comply with the following:

- Finished excavation surfaces shall be in uniform planes, with no abrupt breaks.
- Positive drainage shall be maintained away from the tracks and track subgrade at all times.
- Backfilling materials, procedures, placement and performance criteria shall meet the requirements of SCRRRA Standard Specifications for Earthwork Section 02300 and other applicable specification including hot mix asphalt concrete sub-ballast and aggregate base sub-ballast.

Jacking and receiving pits for installation of culverts or utility casings shall be a minimum of 25 feet from centerline of the nearest active track. Construction activities on SCRRRA Right-of-Way and excavations for jacking and/or boring operations shall comply with all other provisions of these Guidelines as applicable.

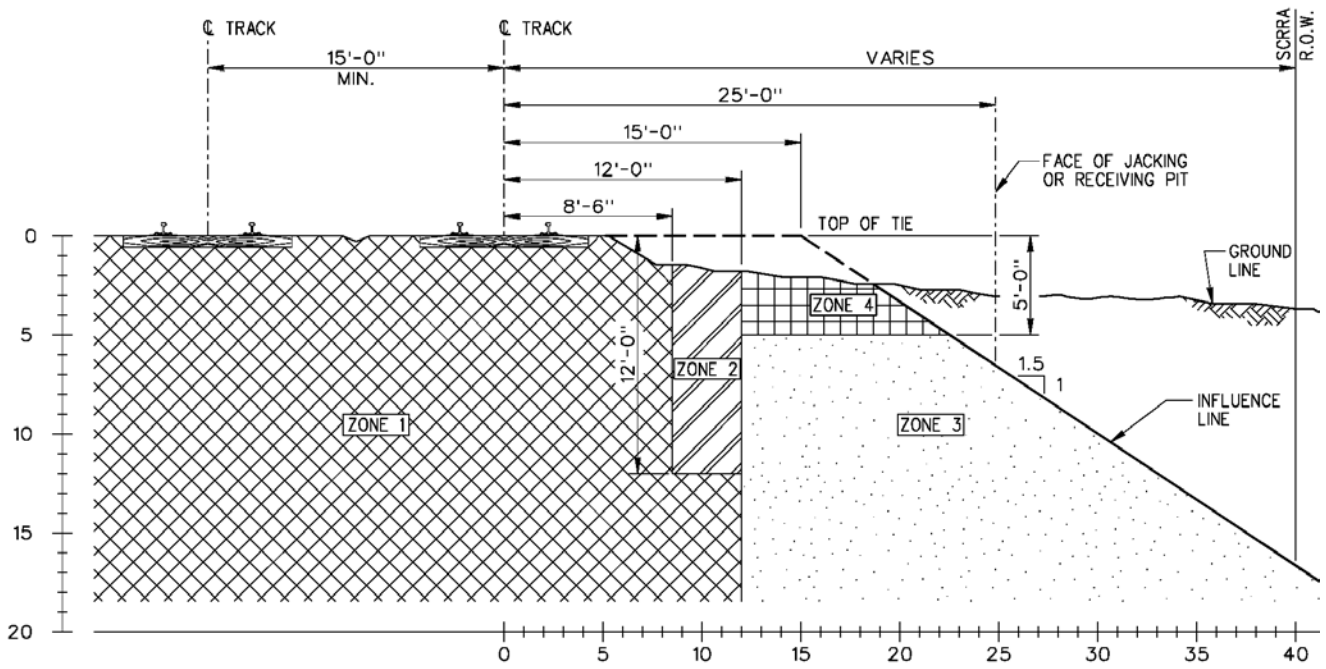

SECTION

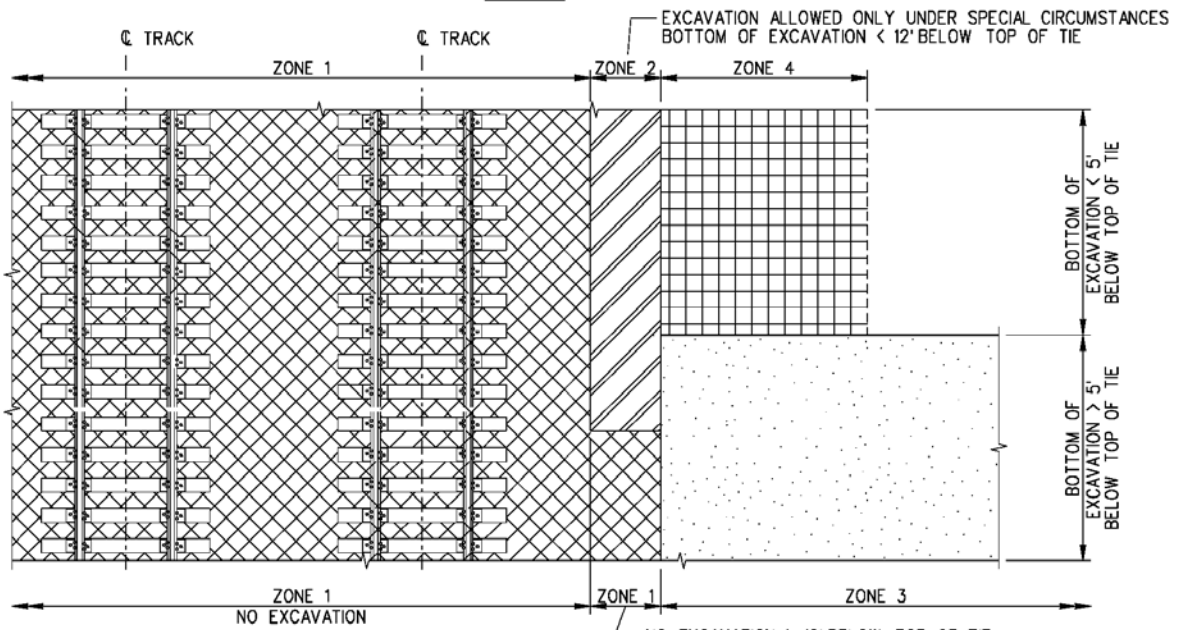

PLAN

Figure 2-1: Railroad Zone of Influence



2.2 VARIANCES

SCRRA prohibits excavation in Zone 1 and does not allow excavation in Zone 2 without special written permission. Variances for allowing excavation within these prohibited areas may be granted on a case-by-case basis by SCRRA at its sole discretion. Planning, design and bidding shall not be based on the assumption that a variance will be granted to allow shored excavation or that an Exclusive Track Window will be approved.

The following minimum requirements shall be met for excavation and backfilling in Zone 1 under an Exclusive Track Window requested in accordance with Section 10.2:

- Excavation and backfilling must be completed during a single, uninterrupted period of time during which no train movements will occur on the track(s).
- Typically, these activities will be restricted to nights and weekends and limited to 4-6 hours or less. Exclusive Track Window requests with durations of more than 12 hours will not be considered.
- Backfilling materials, procedures, placement and performance criteria shall meet the requirements of SCRRA Standard Specifications for Earthwork Section 02300.
- The SCRRA will typically require that a hot mix asphalt concrete (HMAC) sub-ballast layer, 8 inches thick, 12 feet wide centered on the track center line, and extending 20 feet in both directions past the length of the shored excavation be installed. The nominal thickness of the ballast above the HMAC layer and below the bottom of the tie shall be 6 inches.
- SCRRA shall be compensated for the full cost of removing and replacing track and ballast and any other work deemed necessary by SCRRA to provide safe and fully operational track. The Contractor will be required to install the HMAC sub-ballast layer.
- SCRRA shall be compensated for the full cost of having a qualified inspector on site throughout the duration of the work.

The following additional minimum requirements for shored excavations in Zone 2 above and beyond the other requirements of these Guidelines shall be met for variances requested in accordance with Section 10.3:

- Excavation shall have a length parallel to the track no greater than 100 feet.
- Vertical excavations with continuous shoring walls are required.
- A hot mix asphalt concrete (HMAC) sub-ballast with dimensions described above will typically be required.
- Shoring installation shall be complete prior to any excavation.
- Depth of excavation shall be limited to 12 feet below top of tie.
- Time that excavation remains open shall be limited to 30 days.
- Supplemental monitoring of the track will be required.

2.3 EXCEPTIONS FOR MINOR CONSTRUCTION

SCRRA may permit unshored excavation within the Railroad Zone of Influence provided that the excavation has a limited plan area and is no greater than 5 feet in depth. Further, excavation and backfilling must be completed during a single, uninterrupted period of time during which no train movements will occur on the adjacent track. Planning and bidding shall not be based on



the assumption that an exception to the Railroad Zone of Influence shoring requirements will be granted.

Unshored excavation adjacent to a track will only be allowed in soil conditions that will permit the work to be performed without disturbing the adjacent track and/or the materials supporting the track.

Localized shallow trenching for utility installation and excavations for the installation of precast concrete foundations (such as signal foundations) are examples of cases where exceptions may be granted. Exceptions will be granted on a case-by-case basis by SCRRA at its sole discretion. Factors SCRRA will consider when assessing whether or not to grant an exception include: the length of time required to complete the excavation and backfilling, the available time between train movements on the adjacent track, and local soil conditions.

2.4 RIGHT-OF-ENTRY AGREEMENTS

In order to perform work on Right-of-Way that is operated and maintained by SCRRA, Right-of-Entry Agreements are required. For temporary or short-term uses of Right-of-Way, such as surveying activities and shallow geotechnical investigations, the Public Agency or Contractor is required to submit SCRRA Form 5 – Indemnification and Assumption of Liability Agreement. For projects involving construction on SCRRA Right-of-Way, the Public Agency or Contractor is required to enter into SCRRA Form 6 – Temporary Right-of-Entry Agreement. This agreement defines the nature of the work, the flagging requirements, and the appropriate safety measures that must be in place during the work. This includes all work within the Right-of-Way, from initial design through the completion of construction. Additionally, the movement of oversize vehicles over SCRRA maintained and operated crossings requires a fully executed SCRRA Form 4 – Agreement for Moving Oversized Loads Over Highway-rail grade Crossings. These agreements are available on the SCRRA web site: www.metrolinktrains.com.

2.5 RIGHT-OF-WAY

Railroad Right-of-Way, in many cases, is maintained by SCRRA and owned in fee by the Member Agencies. Public Agency or Third Party projects that affect the Right-of-Way must be coordinated with SCRRA Rail Corridor Crossings and Encroachment (C&E) Division. The procedures for applying for Right-of-Way encroachment, and the appropriate forms are found in Form 36 – Right-of-Way Encroachment Approval Procedures, available on the SCRRA web site: www.metrolinktrains.com.

Excavation work will often have an effect on the existing Right-of-Way. The Public Agency shall determine the status of the Right-of-Way within the limits of the project at the earliest stages of the project in order to properly identify the encumbrances and issues related to any proposed excavation. The application of these SCRRA Guidelines to proposed excavations may result in the need for additional Right-of-Way. In cases where additional Right-of-Way is required, the Engineer in Responsible Charge shall develop the appropriate mapping and Right-of-Way definition in accordance with SCRRA standards for the proper definition of the Right-of-Way. The Public Agency shall take the lead for land acquisition. The Engineer in Responsible Charge shall properly define the necessary Right-of-Way, provide legal descriptions, and work with SCRRA's Right-of-Way administrator, and the Member Agency's real estate department, as needed, to advance the process of property acquisition, easement or preparing a license



agreement.

In some cases, SCRRA also shares Right-of-Way with BNSF Railway Company (BNSF) and Union Pacific Railroad (UPRR). In order to perform work on their Right-of-Way, approval shall also be obtained from BNSF or UPRR.

2.6 UTILITIES

Existing utilities shall be located prior to commencing any excavation. Acceptance of the project by SCRRA does not constitute a representation as to the accuracy or completeness of location or the existence or non-existence of any utilities or structures within the limits of the project. The appropriate regional notification center [Underground Service Alert of California (DIGALERT) at (800) 227-2600 or 811], railway companies and utility companies shall be notified prior to performing any excavation close to any underground pipeline, conduit, duct, wire or other structure. Refer to the SCRRA web site: www.metrolinktrains.com to ensure proper contacts and phone numbers. SCRRA is not a member of DIGALERT; it is, therefore, necessary to call the SCRRA signal department phone number to mark, at Public Agency or Contractor expense, signal and communication cables and conduits. In case of signal emergencies, the Contractor shall call the SCRRA 24-hour signal emergency number. If utilities cannot be located, potholing shall be performed to locate the utilities. SCRRA and appropriate utility owners shall be notified immediately when utility lines that were not known or indicated on the drawings are encountered. No service shall be disrupted until the utility owner and SCRRA have determined the required action on such lines.

2.7 SAFETY REGULATIONS

Specific safety regulations of SCRRA are provided in the *Right-of-Entry Agreement and General Safety Regulations for Third Party Construction and Maintenance Activity on SCRRA Member Agency Property*. In addition to safety regulations specific to SCRRA, all construction shall conform to the applicable safety provisions of the latest U.S. Department of Transportation, Federal Railroad Administration (FRA) – *Code of Federal Regulations (CFR), Title 49, Part 214, Railroad Workplace Safety*, and Cal/OSHA Standards – *California Code of Regulations, Title 8, Chapter 4, Division of Industrial Safety, Subchapter 4, Construction Safety Orders*. Construction shall also conform to the applicable California Public Utilities Commission (CPUC) General Orders, as well as any other applicable government agency safety regulations.

2.8 CONSTRUCTION

Construction of excavations or temporary shoring systems within the Basic Safety Envelope or with the potential of entering the Basic Safety Envelope requires a Site Specific Work Plan (SSWP). See Section 10.8 for SSWP submittal requirements. Once the applicable right-of-entry requirements, safety training requirements, and an accepted SSWP are in-place, the Contractor may proceed with construction according to the design plans, specifications and accepted SSWP. The Contractor or Public Agency shall notify SCRRA 30 working days prior to beginning work on the Right-of-Way.

Any damage to rails, ties, structures, embankments, Third Party property, signal and communications equipment, or any other facilities during construction shall be repaired, at the expense of the Public Agency or Contractor, to a condition equal to or better than the condition



prior to entry and to a level accepted by SCRRRA. The Public Agency or Contractor agrees to reimburse SCRRRA and any affected operating railroads for any and all costs and expenses incurred as a result of their work, which may result in the following:

- Unscheduled delay to trains or interference in any manner with the operation of trains.
- Unscheduled disruption to normal railroad operations.
- Unreasonable inconvenience to the public or private users of the system.
- Loss of revenue.
- Alternative method of transportation for passengers.

The Public Agency and Contractor shall comply with the rules and regulations contained in the current editions of the SCRRRA documents listed below during construction. The following documents are available on the SCRRRA web site: www.metroinktrains.com:

- Temporary Right-of-Entry Agreement (Form 6)
- Rules and Requirements for Construction on Railroad Property (Form 37)
- General Safety Regulations for Third Party Construction and Maintenance Activity on SCRRRA Member Agency Property
- Applicable SCRRRA Engineering Standards

2.9 CONTRACTOR OPERATING RESTRICTIONS

When operating near active tracks, whether on or off SCRRRA Right-of-Way, the Contractor's operations will be constrained as necessary to protect the Operating System. In general terms, if the Contractor's operation has the potential to interfere with the safe passage of rail traffic or has the potential to foul the track, restrictions will be imposed on the Contractor's operations.

When working within the Basic Safety Envelope (i.e., within 25 feet of the centerline of the nearest active track), the Contractor is considered to have the potential to foul the track, regardless of the operation or equipment being used.

The Contractor will still be considered as having the potential to foul the track when working outside the Basic Safety Envelope, depending upon the operation. For example, if the Contractor operates a crane or backhoe with a boom sufficient in length to foul a track if the boom were in the horizontal position, or if the Contractor is handling long beams or piles that could fall across a track, such an operation would be restricted.

SCRRRA shall have sole discretion to determine if the Contractor's operation has the potential to foul a track.

Unless otherwise approved by SCRRRA, the Contractor will not be permitted to perform operations that have the potential to foul mainline tracks during weekday commute hours, and must work around the weeknight and weekend train traffic.

SCRRRA may operate work trains along the corridor for the Contractor on various construction projects. The work trains transport a variety of equipment and materials for these projects. The time and number of work train traffic will vary.

The Contractor's activities that have the potential to foul the tracks (mainline or otherwise) will be suspended during all train movements within the construction limits.



The Contractor will generally be directed by SCRRA flagmen as to the need to suspend operations. The number of flagmen required will be determined by SCRRA per its review of the Contractor's SSWP.

All shoring work within the Basic Safety Envelope shall be performed in accordance with an accepted SSWP.

2.10 PROTECTIVE DIVIDERS

A protective divider shall be provided between the construction operations and the Operating System if approved by SCRRA. The divider shall be placed and secured a minimum of 10 feet clear from the centerline of the nearest active track.

Caltrans temporary railing Type K (K-rail) is an acceptable divider. SCRRA prefers that protective dividers have fence installed to 10 feet above ground line.

2.11 HANDRAILS AND WALKWAYS

Adequate physical protection barrier shall be provided for all excavations in accordance with Cal/OSHA requirements.

In the event that there is insufficient space to place a protective divider as specified in Section 2.10, a handrail shall be provided along the side of the excavation adjacent to the track. The preferred clearance from the centerline of the nearest track is 10'-0".

In the event that there would be insufficient clearance to handrail placed along the side of the excavation adjacent to the track, walkway and handrail shall be provided. Walkway shall consist of a slip resistant surface supported by and securely fastened to supports with fasteners that do not extend above the walkway surface. Walkway supports may be connected to and supported by shoring walls. The walkway surface shall be even with the top of shoring.

Handrails and walkways shall be designed in conformance with the requirements of Section 8.5 "Walkways and Handrails on Bridges" of the AREMA *Manual for Railway Engineering*.

2.12 CLEARANCES

All elements of the shoring system shall be placed such that they satisfy the clearance requirements specified in CPUC General Order 26-D.

The preferred clearance from centerline of track to fixed objects such as posts, poles, signs, and elements of shoring systems that extend above the top of rail is 10'-0".

2.13 SHORING REMOVAL

At the conclusion of construction, staged backfill and removal will often be necessary to safely remove bracing and connection elements of the shoring system. Removal of these elements shall be included as part of the shoring construction sequence and the Contractor shall comply with removal requirements as stated on the drawings. Contractor removals shall not proceed if



safety of operations is jeopardized or if SCRRA determines that safety could be jeopardized.

Vertical shoring elements (sheet piles, soldier piles, and diaphragm walls) shall be left in place unless otherwise approved by SCRRA. Vertical shoring elements shall be cut off or demolished to five (5) feet below railroad subgrade if within fifteen (15) feet horizontally from centerline of track or otherwise to five (5) feet below finished ground surface. All other elements of the shoring system shall be completely removed if it is safe to do so and if the risks of track settlement or movement are low. If other elements of the shoring system cannot be completely removed, then at a minimum, they shall be removed to five (5) feet below railroad subgrade if within fifteen (15) feet horizontally from centerline of track or otherwise to five (5) feet below finished ground surface.

If the Contractor desires complete removal of vertical shoring elements for salvage or reuse, the Contractor shall submit the proposed removal procedure along with a completed Design Exception Form (see Appendix C) to SCRRA. The proposed removal procedure shall include provisions that will prevent movement or settlement of the track(s) and fill all voids that might remain after shoring removal. Complete removal of vertical shoring elements may be allowed by SCRRA at their sole discretion.



3.0 Temporary Shoring Systems

3.1 OWNER-DESIGNED TEMPORARY SHORING REQUIREMENT

For construction projects that will require temporary shored excavation within the Railroad Zone of Influence, SCRRA requires that Contract Documents (plans, specifications and estimates) include detailed design drawings and specifications for the temporary shoring system. In addition to clarifying the required construction sequence, defining the impacts to the Operating System and having a temporary shoring system accepted by SCRRA prior to the onset of construction, uncertainty regarding the time and expense required for the Contractor to prepare a temporary shoring submittal that satisfies SCRRA requirements may be effectively eliminated. Specifications shall incorporate provisions of SCRRA Standard Specifications for Excavation and Excavation Support Systems Section 02160. These specifications allow for Contractor-designed alternates to be submitted to SCRRA for review and acceptance prior to construction.

3.2 PREFERRED SHORING TYPES AND ELEMENTS

The following types of shoring are preferred by SCRRA for use within the Railroad Zone of Influence:

- **Continuous Shoring Walls versus Soldier Piles and Lagging:** Because they are completed in place prior to any excavation, continuous shoring walls (such as sheet piling and diaphragm walls) are preferred over soldier piles and lagging. When soldier pile and lagging systems are utilized, lagging members are installed as excavation proceeds. During the excavation process, vertical cuts (of limited extent) are required to stand unsupported until the lagging has been installed. During the time the ground is unsupported, raveling or ground loss can result in ground settlements that negatively impact track profile and alignment. Additionally, if the lagging is not installed tight to the excavated ground, the ground will tend to move to fill the gaps, which can result in settlement behind the shoring wall that negatively impacts track profile and alignment. Consequently, the chance of ground loss that could undermine or settle the tracks is significantly reduced when continuous shoring walls are used.
- **Deep Soil Mix Walls versus Sheet Piling:** It has been SCRRA's experience that the soil mixing (drill) rig and other equipment utilized during a soil mixing operation typically pose a lesser risk to SCRRA than the pile driving equipment utilized to install sheet piling. Additionally, pre-drilling and vibration associated with sheet pile installation and extraction can cause track settlement. Consequently, the Contractor's operations may be somewhat less restricted if deep soil mix walls are used in lieu of sheet piling.
- **Preloaded Bracing:** Preloading of bracing elements can reduce shoring deflection and ground settlement during excavation and assure good bearing and a tight fit between shoring elements. Where feasible, struts shall be preloaded to about 50% of their design load to achieve adequate bearing between connected shoring elements and to reduce the track settlement that can occur during excavation.



3.3 PROHIBITED SHORING TYPES AND ELEMENTS

The following types of shoring are prohibited from use within the Railroad Zone of Influence:

- Soil Nailing: Soil nailing shall not be utilized to shore excavations within the Railroad Zone of Influence. In addition, soil nails shall not extend into the Railroad Zone of Influence from walls supporting excavations outside of the Railroad Zone of Influence.
- Helical Screw Anchors: Helical Screw Anchors shall not be utilized to shore excavations within the Railroad Zone of Influence. In addition, helical screw anchors shall not extend into the Railroad Zone of Influence from walls supporting excavations outside of the Railroad Zone of Influence.



4.0 Loading on Temporary Shoring Systems

4.1 GENERAL

Lateral loading from the following sources shall be considered in the design of the temporary shoring system:

- Retained Soil
- Retained Groundwater (hydrostatic pressure)
- Surcharge from all applicable sources, including, but not limited to, railroad live load, equipment and vehicles, material stockpiles, structures and improvements, etc.

Additionally, under certain conditions, earthquake (seismic) loading shall be considered. See Section 4.5.

Other sources of load, including centrifugal force from a train, impact loads, thermal loads, and wind loads are typically not required to be considered in the design of shoring. Such loads need only be considered in cases where they are significant. For example, centrifugal forces may need to be considered in the design of a shoring system constructed at a curve over which trains travel at high speeds.

4.2 SOIL LOADS

The following examples are located within Appendix B

- Example 4.1 Develop an Active Soil Pressure Diagram
- Example 4.2 Develop an Apparent Pressure Diagram
- Example 4.3 Determine Passive Resistance (Cohesionless Soil)
- Example 4.4 Determine Passive Resistance (Cohesive Soil)

4.2.1 Soil Types and the Determination of Soil Properties

Soil types and applicable properties shall be ascertained by taking borings and performing appropriate field and laboratory tests. Sufficient geotechnical exploration shall be performed to establish an understanding of the soil profile for the subject site. In addition to establishing the soil profile, key soil parameters for the design of shoring to be ascertained during exploration include the unit weights and strengths for the soils [i.e., the cohesion (c) and angle of internal friction (Φ)].

The design soil properties shall be established by a Registered Geotechnical Engineer, or, alternatively, by a Registered Civil Engineer specializing in geotechnical engineering.

4.2.2 Loading from Retained Soil on Flexible Systems

The loading defined in this section applies to shoring systems that have some degree of flexibility. Shoring types that may be considered flexible include cantilever shoring walls and, in most cases, shoring walls supported by a single level of bracing. The active soil pressure



distribution for a flexible shoring system shall be assumed to take the form of an equivalent fluid pressure (EFP); i.e., a triangularly shaped pressure distribution.

EFP values used for shoring design shall be ascertained by a Registered Geotechnical Engineer, or, alternatively, by a Registered Civil Engineer specializing in geotechnical engineering. In no case shall the design active EFP for soil above the groundwater table be less than 30 psf/ft for level retained earth when this approach is used (i.e., the active pressure at any depth shall not be less than 30(Y) psf where Y is a depth below the ground surface in feet). This minimum EFP value must be increased appropriately when the shoring system is retaining a sloped cut.

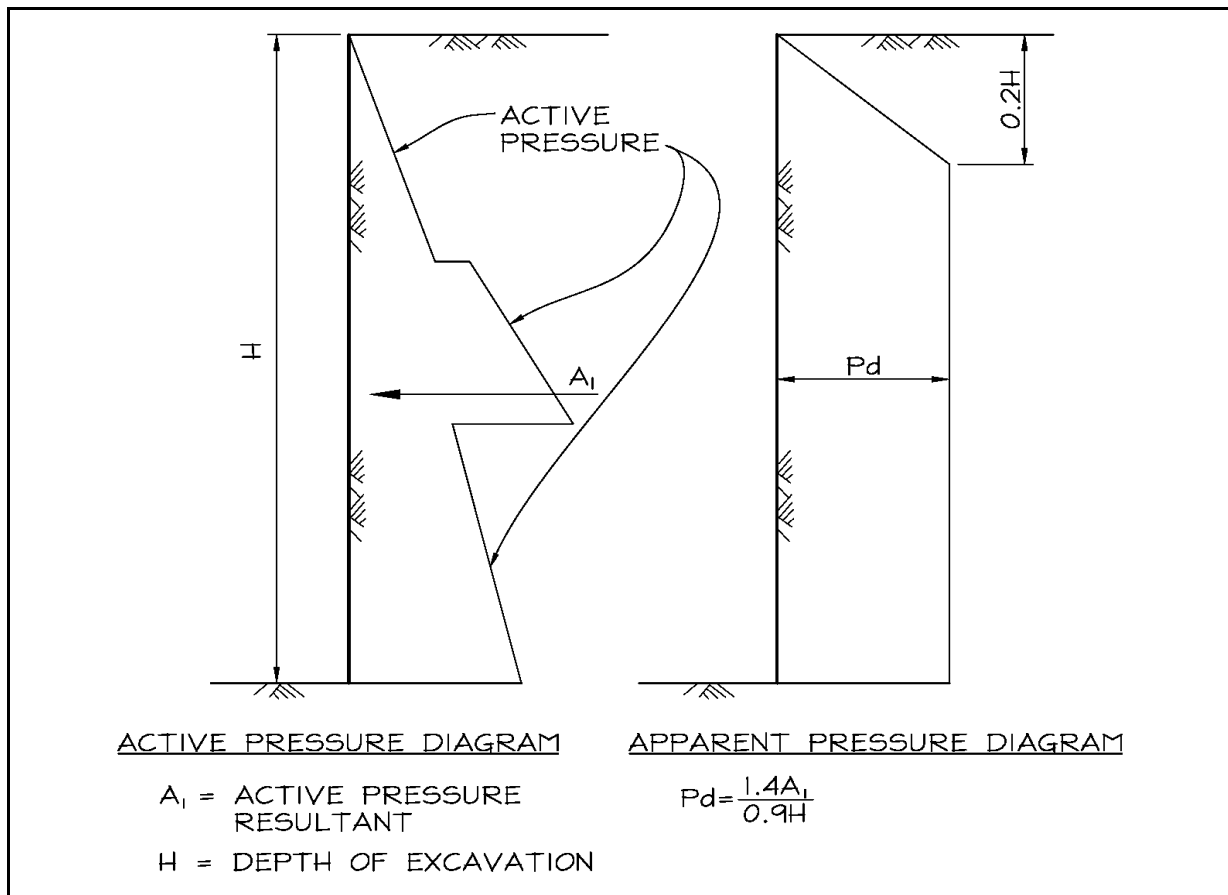

Figure 4-1: Construction of an Apparent Pressure Diagram

Alternatively, the retained soils may be classified as either Type 2, 3, 4 or 5 in accordance with the soil descriptions in Table 8-5-1 of the AREMA *Manual for Railway Engineering*. Representative soil properties for each classification are given in Table 8-5-2 of the AREMA *Manual for Railway Engineering*. The soil properties for the Type 1 classification given in Table 8-5-2 shall not be used. In no case shall the design EFP for soil above the groundwater table be less than 37 psf/ft for level retained earth when this approach is used (i.e., the active pressure at any depth shall not be less than 37(Y) psf where Y is a depth below the ground surface in feet). This EFP corresponds to Type 2 soil classification. This minimum value must be increased appropriately for the case of shoring that is retaining a sloped cut.



4.2.3 Loading from Retained Soil on Restrained Systems

Shoring walls with multiple levels of bracing tend to restrict movements of the soil behind the wall. This restraint alters the soil pressure distribution from that anticipated based on the theory of active loading. “Apparent pressure” diagrams for braced (restrained) shoring systems have been developed by numerous authors. Generalized apparent pressure diagrams suitable for use in both cohesionless and cohesive soils, as well as interlayered soil profiles, can be constructed from active pressure diagrams as shown in Figure 4-1.

Alternatively, a number of diagrams, applicable to either cohesionless or cohesive soils, are presented in Chapter 5 of the Caltrans *Trenching and Shoring Manual*. These diagrams may be utilized, provided that the resulting loading magnitudes are not significantly less conservative than those determined by the procedure outlined in Figure 4-1.

When apparent pressure loading is utilized for design, active soil loading developed in accordance with Section 4.2.2 shall be assumed to act below excavation grade.

4.2.4 Passive Resistance

Cohesionless Soil

The passive resistance in cohesionless ($c = 0$) soils shall be determined based upon log-spiral theory (refer to Figure 8 in the Caltrans *Trenching and Shoring Manual*). Determination of the coefficient of passive pressure (K_p) is a function of Φ and the angle of wall friction (δ).

Previous railroad design criteria have required that δ be assumed to be 0° due to dynamic train loading. However, this assumption can produce overly conservative results. In lieu of requiring $\delta = 0^\circ$, at the shoring designer’s option, δ_{design} may be assumed to be a maximum of $\delta_{\text{typ}}/2$, where δ_{typ} is the wall friction value that would be utilized in the design of typical shoring away from railroad tracks. In no case shall δ exceed $\Phi/4$.

Cohesive Soil

In cohesive ($\Phi = 0^\circ$) soil, $K_p = 1.0$, and the passive resistance is $\gamma_e z + 2c$, where γ_e is the effective unit weight of the soil (i.e., the moist unit weight above the water level and the buoyant unit weight below the water level) and z is a depth below excavation grade.

Negative active pressures shall not be utilized to increase the available passive resistance under any circumstances. (Negative active pressures can be computed when $2c$ exceeds $\gamma_e H$, where H is the depth of excavation.)

c, Φ Soil

Passive pressure diagrams can be developed for c, Φ soils using more complex theoretical expressions. However, it is common to consider a soil stratum as either a purely cohesionless or cohesive soil depending on the soil’s predominant physical properties and expected behavior.

Effect of Unbalanced Water Head



In cases where the shoring system will retain an unbalanced water head, available passive resistance may need to be reduced to account for upward seepage pressures.

4.3 GROUNDWATER LOAD

Groundwater loading acting on the shoring system shall be based upon the maximum groundwater level that can be reasonably anticipated during the life of the shored excavation.

The design groundwater table shall be established based upon available historical groundwater monitoring (well) data and/or boring data for the subject area. For projects where historical records are not available, the groundwater table utilized for design should be assessed conservatively.

4.4 SURCHARGE LOADS

Lateral pressure acting on the temporary shoring system resulting from the following sources of surcharge loading shall be considered in the design of the shoring as appropriate:

- Railroad live load (see Section 5)
- Track, ties and ballast (where not included in soil loads)
- Equipment and vehicles
- Material stockpiles
- Existing structures
- Any other source of surcharge load

Lateral pressure resulting from vertical surcharge loads should be computed in accordance with the equations presented in Section 20.3.2 of the AREMA Manual for Railway Engineering.

4.5 EARTHQUAKE (SEISMIC) LOAD

In atypical situations, such as where a shored excavation of substantial length parallels the Operating System or where a shored excavation will remain open for more than 3 months, SCRRA may require that lateral loading due to earthquake (seismic) shaking be considered. Subway construction parallel to the tracks is an example of a situation where the application of earthquake loading may be appropriate because an extensive length of open excavation may be present at one time.

This issue will be addressed on a project-specific basis by SCRRA.

4.6 COMBINATION OF LOADS AND LOADING CASES

All elements of the temporary shoring system shall be designed for a combination of lateral soil, groundwater, and surcharge loads acting in conjunction with vertical dead and live loads.

Loading conditions during all stages of excavation, support removal and support relocation shall be analyzed. No reduction in loading from that present during the full depth excavation stage shall be assumed for the stages of support removal or relocation.



In situations where loading conditions on opposite sides of an internally braced excavation are not equal, the shoring design shall account for this unbalanced loading condition. The shoring system shall be designed for, and be compatible with, the more heavily loaded side of the excavation.



5.0 Railroad Live Load Surcharge

5.1 GENERAL

All temporary shoring systems supporting excavations within Zones 1, 2 and 3 of the Railroad Zone of Influence (see Section 2) shall be designed for lateral pressure due to railroad live load surcharge. Railroad live load surcharge shall be based on Cooper's E-80 live load. Lateral pressure resulting from railroad live load surcharge shall be computed using the Boussinesq equation (see Figure 5-1). No reduction in lateral surcharge pressure shall be allowed for "flexible" or "semi-rigid" wall behavior, typically 50% and 75% in non-railroad applications, respectively (i.e. 100% Boussinesq live load surcharge for "rigid" wall behavior is required for design of all shoring wall types).

Lateral surcharge pressure values for various depths below bottom of tie and distances to centerline of track computed using the Boussinesq equation are provided in Table 5.1.

The values in Table 5.1 were developed for the standard wood tie length (TL) of 9.0 feet. The values developed for the standard concrete tie length (8.25 feet) are not meaningfully different from those presented in Table 5.1. Note that the tabulated values apply only for situations where the top of shoring is at or above the elevation of the bottom of railroad ties.

The following examples are located in Appendix B

- Example 5.1 Railroad Live Load Surcharge from Two Tracks
- Example 5.2 Railroad Live Load Surcharge from Three Tracks
- Example 5.3 "Simplified" Railroad Live Load Surcharge

5.2 SURCHARGE FROM MULTIPLE TRACKS

Surcharge loading from multiple tracks shall be considered as follows:

- Two tracks – Full surcharge from both tracks.
- Three tracks – Full surcharge from two closest tracks combined with 50% surcharge from third track.
- Four or more tracks – Full surcharge from two closest tracks combined with 50% surcharge from third track and 25% surcharge from fourth track.

Only surcharge from those tracks for which the shored excavation is within the Railroad Zone of Influence need be considered.

5.3 SIMPLIFIED SURCHARGE PRESSURE DISTRIBUTION

In lieu of using the detailed Boussinesq pressure distribution, railroad live load surcharge pressures may be assumed to have a rectangular distribution with a magnitude equal to 80% of the maximum Boussinesq pressure.

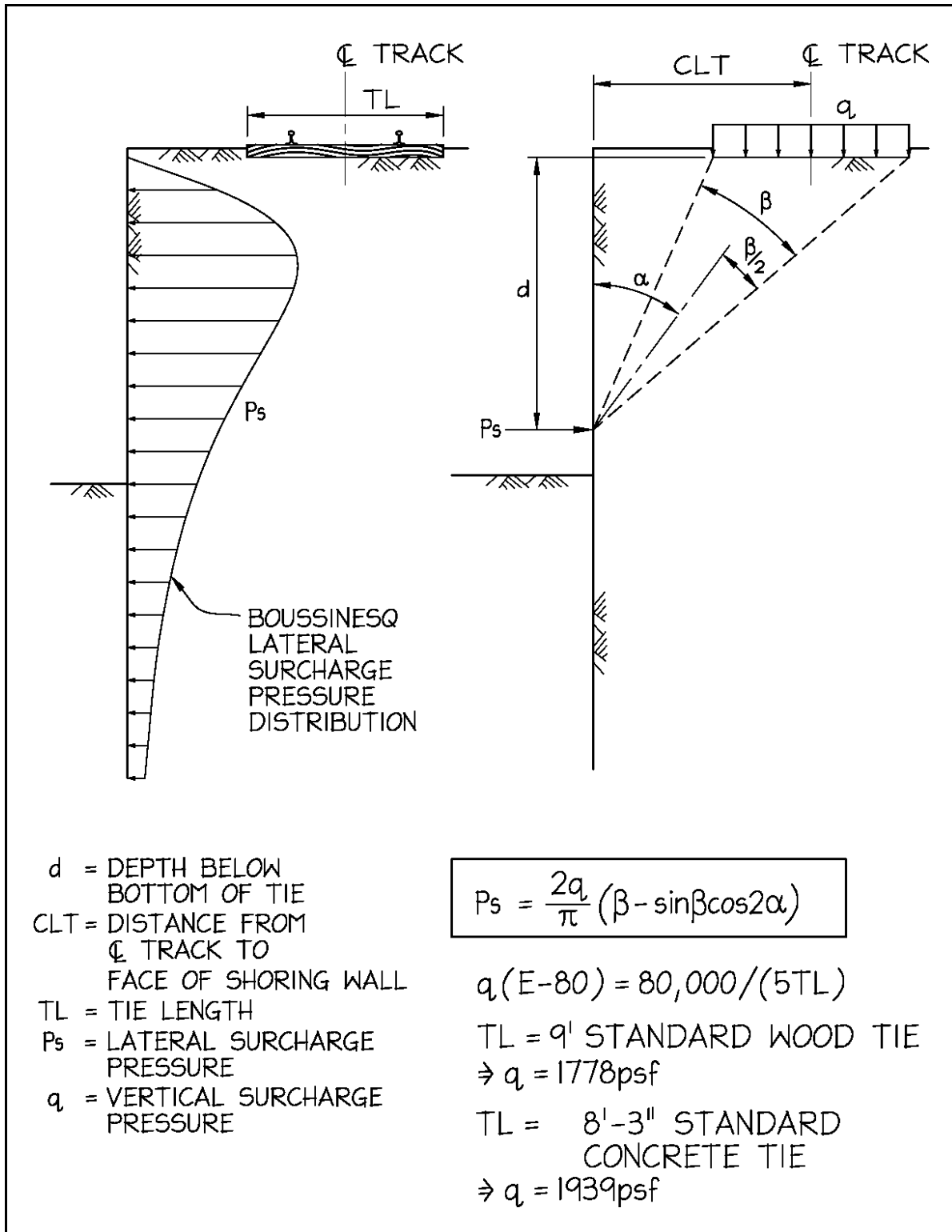

Figure 5-1: E-80 Railroad Live Load Surcharge Using the Boussinesq Equation



5.4 APPLICATION OF SURCHARGE PRESSURES

Railroad live load surcharge pressures shall be assumed to act over the full height of the temporary shoring wall. Where the top of the shoring wall is at or above the bottom of railroad tie elevation, the vertical surcharge pressure (q) used in the Boussinesq distribution shall be the pressure under the ties and shall be applied starting at the bottom of tie elevation. Where the top of the shoring wall is below the bottom of railroad tie elevation, the vertical surcharge pressure used in the Boussinesq distribution shall be an equivalent pressure at the top of the shoring wall. The equivalent vertical surcharge pressure shall be distributed over a length equal to the tie length plus the vertical distance from bottom of tie to top of wall (1H:2V distribution outward from each end of the tie). The magnitude of the equivalent vertical surcharge (q) will be equal to the pressure under the tie multiplied by the ratio of the tie length to the equivalent distributed length.

5.5 SURCHARGE FOR PERPENDICULAR SHORING WALLS

When temporary shoring walls are to be installed perpendicular to the centerline of track or used as temporary bridge abutments, the design railroad live load surcharge acting on such walls shall be computed in accordance with Chapter 8, Section 5.3.1 of the *AREMA Manual for Railway Engineering*.

5.6 COMBINATION WITH SURCHARGE FROM OTHER SOURCES

Surcharge from other sources (e.g., heavy equipment, existing structures, etc.) shall be considered in the design of temporary shoring systems for excavation support as appropriate. Surcharges from other sources shall be added to the railroad live load surcharge if the surcharge loads can act concurrently. An example of combined surcharges may be Contractor cranes, trucks, or material stockpiles above an excavation concurrent with a passing train.



TABLE 5.1 - RAILROAD (E-80) LIVE LOAD LATERAL SURCHARGE

Based on the Boussinesq equation (see Figure 5-1)

d = depth below bottom of tie

surcharge values in psf

d (feet)	distance from centerline of track to face of shoring (feet)																
	5	6	7	8	8.5	9	10	11	12	13	14	15	16	17	18	19	20
1	1469	974	625	434	370	320	247	197	161	135	114	98	86	75	67	59	53
2	1304	1172	930	719	635	563	450	367	305	257	220	191	166	147	130	117	105
3	1103	1092	983	838	767	701	585	492	418	359	310	271	239	212	189	170	153
4	921	955	924	846	799	750	655	570	496	434	381	337	299	267	240	217	197
5	762	817	828	797	771	741	674	605	541	482	431	386	347	313	283	257	234
6	629	692	724	725	715	699	658	609	558	508	461	419	381	347	317	290	266
7	518	583	627	646	646	642	622	591	553	514	475	438	403	371	341	315	291
8	428	491	539	568	576	580	575	559	535	506	476	444	414	385	358	333	309
9	354	413	462	497	509	518	525	520	507	488	466	441	416	391	367	344	322
10	295	349	396	434	448	460	474	479	474	464	449	431	411	390	370	349	329
11	246	295	340	378	394	407	426	437	439	436	427	415	400	384	367	349	332
12	207	251	293	330	345	359	382	396	404	406	403	396	386	373	360	346	331
13	175	215	253	288	303	317	341	359	370	376	377	374	368	360	350	338	326
14	149	184	219	252	267	281	305	324	338	347	351	352	349	344	337	329	319
15	127	159	190	221	235	248	272	292	307	319	326	329	330	328	323	317	310
16	110	138	166	194	207	220	243	263	280	292	301	307	310	310	308	305	300
17	95	120	146	171	184	196	218	237	254	268	278	285	290	293	293	291	288
18	82	105	128	151	163	174	195	214	231	245	256	265	271	275	277	277	276
19	72	92	113	134	145	155	175	194	210	224	236	246	253	258	261	263	263
20	63	81	100	120	129	139	158	175	191	205	217	228	236	242	246	249	250
21	56	72	89	107	116	125	142	159	174	188	200	211	219	226	232	235	238
22	49	64	79	96	104	112	129	144	159	172	184	195	204	211	217	222	225
23	44	57	71	86	94	101	116	131	145	158	170	181	190	198	204	209	213
24	39	51	64	77	84	92	106	119	133	145	157	167	176	185	191	197	202
25	35	46	58	70	76	83	96	109	122	134	145	155	164	172	179	185	190
26	32	41	52	63	69	75	88	100	112	123	134	144	153	161	168	174	180
27	29	37	47	58	63	69	80	91	102	113	124	133	142	150	158	164	170
28	26	34	43	52	58	63	73	84	94	105	114	124	132	141	148	154	160
29	23	31	39	48	53	57	67	77	87	97	106	115	123	131	139	145	151
30	21	28	36	44	48	53	62	71	80	89	98	107	115	123	130	137	142
31	19	26	33	40	44	48	57	65	74	83	91	100	108	115	122	128	134
32	18	23	30	37	41	44	52	60	69	77	85	93	101	108	115	121	127
33	16	22	27	34	37	41	48	56	64	71	79	87	94	101	108	114	120
34	15	20	25	31	35	38	45	52	59	66	74	81	88	95	101	107	113
35	14	18	23	29	32	35	41	48	55	62	69	76	82	89	95	101	107
36	13	17	22	27	30	33	39	45	51	58	64	71	77	84	90	95	101
37	12	16	20	25	28	30	36	42	48	54	60	66	73	79	84	90	95
38	11	15	19	23	26	28	33	39	45	50	56	62	68	74	80	85	90
39	10	13	17	22	24	26	31	36	42	47	53	58	64	70	75	80	85
40	9	13	16	20	22	24	29	34	39	44	50	55	60	66	71	76	81
41	9	12	15	19	21	23	27	32	37	42	47	52	57	62	67	72	77
42	8	11	14	18	19	21	25	30	34	39	44	49	54	58	63	68	73
43	8	10	13	16	18	20	24	28	32	37	41	46	51	55	60	64	69
44	7	10	12	15	17	19	22	26	30	35	39	43	48	52	57	61	65
45	7	9	12	14	16	18	21	25	29	33	37	41	45	49	54	58	62
46	6	8	11	14	15	17	20	23	27	31	35	39	43	47	51	55	59
47	6	8	10	13	14	16	19	22	25	29	33	37	40	44	48	52	56
48	6	7	10	12	13	15	18	21	24	27	31	35	38	42	46	50	53
49	5	7	9	11	13	14	17	20	23	26	29	33	36	40	44	47	51
50	5	7	9	11	12	13	16	19	21	25	28	31	34	38	41	45	48



TABLE 5.1 - RAILROAD (E-80) LIVE LOAD LATERAL SURCHARGE (CONTINUED)

Based on the Boussinesq equation (see Figure 5-1)

d = depth below bottom of tie

surcharge values in psf

d (feet)	distance from centerline of track to face of shoring (feet)																
	21	22	23	24	25	26	27	28	29	30	31	32	33	34	35	36	37
1	48	44	40	37	34	31	29	27	25	23	22	20	19	18	17	16	15
2	95	86	79	72	66	61	57	53	49	46	43	40	38	36	34	32	30
3	139	127	116	106	98	91	84	78	73	68	64	60	56	53	50	47	45
4	179	164	150	138	128	118	110	102	95	89	84	79	74	70	66	62	59
5	214	197	181	167	155	144	134	125	117	109	103	96	91	86	81	77	73
6	244	225	208	193	179	167	156	146	136	128	120	113	107	101	96	91	86
7	269	249	231	215	201	187	175	164	154	145	137	129	122	115	109	104	98
8	288	268	250	234	219	205	192	181	170	160	151	143	135	128	122	116	110
9	302	283	265	249	234	220	207	195	184	174	165	156	148	140	133	127	121
10	311	293	276	260	246	232	219	207	196	186	176	167	159	151	144	137	131
11	315	299	283	269	254	241	229	217	206	196	186	177	168	161	153	146	140
12	316	302	287	274	261	248	236	225	214	204	194	185	177	169	161	154	147
13	314	301	289	276	264	252	241	230	220	210	201	192	184	176	168	161	154
14	309	298	287	276	265	255	244	234	224	215	206	198	189	182	174	167	161
15	302	293	284	274	265	255	246	236	227	218	210	202	194	186	179	172	166
16	293	286	279	271	262	254	245	237	228	220	212	205	197	190	183	176	170
17	284	278	272	265	258	251	244	236	228	221	214	206	199	192	186	179	173
18	273	269	265	259	253	247	241	234	227	220	214	207	201	194	188	182	176
19	262	259	256	252	247	242	237	231	225	219	213	207	201	195	189	183	178
20	250	249	247	244	241	237	232	227	222	217	211	206	200	195	189	184	179
21	239	239	238	236	233	230	227	223	218	214	209	204	199	194	189	184	179
22	227	228	228	227	226	223	221	217	214	210	206	201	197	193	188	183	179
23	216	218	219	219	218	216	214	212	209	206	202	198	195	191	186	182	178
24	205	207	209	210	210	209	208	206	204	201	198	195	192	188	184	181	177
25	194	197	200	201	202	201	201	200	198	196	194	191	188	185	182	179	175
26	184	188	190	192	193	194	194	193	192	191	189	187	184	182	179	176	173
27	174	178	181	184	185	186	187	187	186	185	184	182	180	178	176	173	171
28	165	169	173	175	177	179	180	180	180	180	179	178	176	174	173	170	168
29	156	161	164	167	170	172	173	174	174	174	174	173	172	170	169	167	165
30	148	152	156	160	162	165	166	167	168	168	168	168	167	166	165	164	162
31	140	144	149	152	155	158	160	161	162	163	163	163	163	162	161	160	159
32	132	137	141	145	148	151	153	155	156	157	158	158	158	158	157	156	155
33	125	130	134	138	141	144	147	149	150	152	153	153	153	153	153	152	152
34	118	123	127	131	135	138	141	143	145	146	147	148	149	149	149	149	148
35	112	117	121	125	129	132	135	137	139	141	142	143	144	145	145	145	144
36	106	111	115	119	123	126	129	132	134	136	137	139	139	140	141	141	141
37	100	105	109	114	117	121	124	126	129	131	132	134	135	136	136	137	137
38	95	100	104	108	112	115	118	121	124	126	128	129	131	132	132	133	133
39	90	95	99	103	107	110	113	116	119	121	123	125	126	127	128	129	130
40	85	90	94	98	102	105	109	111	114	116	119	120	122	123	124	125	126
41	81	85	90	94	97	101	104	107	110	112	114	116	118	119	120	121	122
42	77	81	85	89	93	96	100	102	105	108	110	112	114	115	117	118	119
43	73	77	81	85	89	92	95	98	101	104	106	108	110	111	113	114	115
44	69	74	77	81	85	88	91	94	97	100	102	104	106	108	109	111	112
45	66	70	74	77	81	84	87	90	93	96	98	100	102	104	106	107	108
46	63	67	70	74	77	81	84	87	90	92	94	97	99	101	102	104	105
47	60	64	67	71	74	77	80	83	86	89	91	93	95	97	99	100	102
48	57	61	64	67	71	74	77	80	83	85	88	90	92	94	96	97	99
49	54	58	61	65	68	71	74	77	79	82	84	87	89	91	92	94	96
50	52	55	58	62	65	68	71	74	76	79	81	84	86	88	89	91	93



TABLE 5.1 - RAILROAD (E-80) LIVE LOAD LATERAL SURCHARGE

(CONTINUED)

Based on the Boussinesq equation (see Figure 5-1)

d = depth below bottom of tie

surcharge values in psf

d (feet)	distance from centerline of track to face of shoring (feet)												
	38	39	40	41	42	43	44	45	46	47	48	49	50
1	14	14	13	12	12	11	11	10	10	9	9	9	8
2	28	27	26	24	23	22	21	20	19	19	18	17	16
3	42	40	38	36	35	33	32	30	29	28	27	25	24
4	56	53	51	48	46	44	42	40	38	37	35	34	32
5	69	66	62	60	57	54	52	50	47	45	44	42	40
6	82	78	74	70	67	64	61	59	56	54	52	50	48
7	93	89	85	81	77	74	71	68	65	62	60	57	55
8	105	100	95	91	87	83	80	76	73	70	67	65	62
9	115	110	105	100	96	92	88	84	81	78	75	72	69
10	125	119	114	109	104	100	96	92	88	85	82	79	76
11	133	128	122	117	112	108	103	99	95	92	88	85	82
12	141	135	130	124	119	115	110	106	102	98	95	91	88
13	148	142	136	131	126	121	117	112	108	104	100	97	93
14	154	148	142	137	132	127	122	118	114	110	106	102	99
15	159	153	148	142	137	132	127	123	119	115	111	107	103
16	164	158	152	147	142	137	132	128	123	119	115	111	108
17	167	162	156	151	146	141	136	132	127	123	119	115	112
18	170	165	159	154	149	144	140	135	131	127	123	119	115
19	172	167	162	157	152	147	143	138	134	130	126	122	119
20	173	168	163	159	154	149	145	141	137	133	129	125	122
21	174	169	165	160	156	151	147	143	139	135	131	128	124
22	174	170	165	161	157	153	149	145	141	137	133	130	126
23	174	170	166	161	157	153	150	146	142	138	135	131	128
24	173	169	165	161	158	154	150	147	143	140	136	133	129
25	172	168	165	161	158	154	150	147	144	140	137	134	131
26	170	167	164	160	157	154	150	147	144	141	138	135	131
27	168	165	162	159	156	153	150	147	144	141	138	135	132
28	166	163	160	158	155	152	149	146	144	141	138	135	132
29	163	161	158	156	153	151	148	146	143	140	138	135	132
30	160	158	156	154	152	149	147	145	142	140	137	135	132
31	157	155	154	152	150	148	146	143	141	139	136	134	132
32	154	153	151	149	148	146	144	142	140	138	136	133	131
33	151	150	148	147	145	144	142	140	138	136	134	132	130
34	147	146	145	144	143	142	140	138	137	135	133	131	129
35	144	143	142	141	140	139	138	136	135	133	132	130	128
36	140	140	139	139	138	137	136	134	133	132	130	129	127
37	137	137	136	136	135	134	133	132	131	130	129	127	126
38	133	133	133	133	132	132	131	130	129	128	127	126	124
39	130	130	130	130	129	129	128	128	127	126	125	124	123
40	126	127	127	127	127	126	126	125	125	124	123	122	121
41	123	123	124	124	124	124	123	123	122	122	121	120	119
42	119	120	120	121	121	121	121	120	120	119	119	118	117
43	116	117	117	118	118	118	118	118	118	117	117	116	116
44	113	114	114	115	115	115	115	115	115	115	115	114	114
45	109	110	111	112	112	113	113	113	113	113	112	112	112
46	106	107	108	109	109	110	110	110	110	110	110	110	110
47	103	104	105	106	107	107	107	108	108	108	108	108	108
48	100	101	102	103	104	104	105	105	106	106	106	106	106
49	97	98	99	100	101	102	102	103	103	103	104	104	104
50	94	95	97	98	98	99	100	100	101	101	101	102	102



6.0 Shoring Analysis Methodologies

Classic shoring analysis methodologies have been summarized in Section 6.0 and should be considered minimum analysis requirements for temporary shoring design. Computer programs and more advanced soil-structure interaction analyses may be utilized for design, but shall be accompanied by verified hand calculations showing significant agreement with the classic methodologies presented herein. The Engineer in Responsible Charge shall be solely responsible for input and results of computer programs utilized for shoring analysis and design. See Section 10.0 for additional information on submittal of computer program output as part of the design calculations.

Typical temporary shoring applications may not require stability analysis beyond determining the minimum embedment. The factor of safety against sliding, overturning and global slope stability shall be calculated as applicable to the particular temporary shoring system. The minimum factor of safety for stability, including sliding, overturning and global slope stability, shall be 1.5. See Section 8.4 for global stability analysis requirements.

The following examples are provided in Appendix B:

- Example 6.1 Cantilever Soldier Pile and Lagging Shoring Wall
- Example 6.2 Sheet Pile Shoring Wall, One Level of Bracing (Free Earth Support Method)
- Example 6.3 Sheet Pile Shoring Wall, One Level of Bracing (Fixed Earth Support Method)
- Example 6.4 Analysis of a Diaphragm Shoring Wall with Three Levels of Bracing

6.1 CONTINUOUS SHORING WALLS

Continuous shoring walls, such as steel sheet piling and diaphragm walls, are typically analyzed on a longitudinal per-foot-of-wall (unit) basis for the lateral pressures computed in accordance with Sections 4 and 5 of these Guidelines. The wall is designed for the unit bending moments and shears resulting from the lateral pressures acting on the wall. When the shoring wall is designed to support vertical loads, these loads must be considered in the design as well.

In the case of sheet piling, the structural strength of the wall is provided by sheets themselves. Wide flange sections installed in deep soil mix, secant, tangent, or slurry walls are the primary structural elements for these systems. Rebar reinforced slurry walls are designed as a continuous vertically reinforced concrete wall.

6.2 SOLDIER PILE SHORING WALLS

Soldier pile and lagging walls are analyzed in a somewhat different manner than continuous shoring walls. Soldier pile and lagging walls are not continuous below excavation grade, and the loading acting on the active and passive sides of the wall for the embedded portion of the wall must be constructed to reflect the discontinuous nature of the wall. The “effective width” of the embedded portion of the soldier pile (for both active and passive loading) shall be computed using the “Arching Capability” values given in Table 10-1 of the Caltrans *Trenching and Shoring Manual*. As for continuous walls, lateral pressures utilized to construct the loading diagrams shall be computed in accordance with Sections 4 and 5 of these Guidelines.

Soldier piles are designed as vertical beams to resist the bending moments and shears resulting



from the lateral loads acting on the piles. Vertical loading (if any) shall be considered in the soldier pile design.

6.3 ANALYSIS OF CANTILEVER WALLS

Cantilever shoring walls shall be designed using the “Conventional Methods” of analysis illustrated in Figures 8-1 (cohesionless soil) and 8-2 (cohesive soil) of the Caltrans *Trenching and Shoring Manual*.

Alternatively, cantilever walls may be designed using the “Simplified” method illustrated in Figure 8-3 of the Caltrans *Trenching and Shoring Manual*. If this method is used, the computed embedment depth (referred to as D_0 in the above referenced figures) shall be increased by 20 percent to determine the minimum theoretical embedment depth.

“Design Curves” (e.g., Figure 8-4 in the Caltrans *Trenching and Shoring Manual*) shall not be used for the design of cantilever shoring walls within the Railroad Zone of Influence.

A factor of safety for the cantilever wall embedment shall be provided. When the theoretical embedment depth is computed based on the “unreduced” passive resistance (factor of safety equal to 1.0), this theoretical embedment depth shall be increased by a minimum of 40% to determine the design embedment depth (i.e. minimum factor of safety on theoretical embedment depth of 1.4). This 40% increase is provided in addition to the 20% increase required if the “Simplified” method of analysis has been utilized.

Embedment depths computed based on passive resistance that has been divided by a factor of safety of 2.0 will also be acceptable, provided that the resulting embedment depth is not significantly less than that computed using the nominal 40% increase in embedment depth discussed above.

Analysis utilizing “unreduced” passive resistance should be applied with caution when the shoring wall is embedded in stiff to hard clays, because the computed embedment may be unrealistically short. See Section 6.8.1 for minimum embedment depths.

6.4 ANALYSIS OF WALLS WITH A SINGLE LEVEL OF BRACING

Walls supported by a single level of bracing (or a single tier of tiebacks) may be analyzed using the Free Earth Support or Fixed Earth Support Method at the shoring designer’s option. Each of these methods is outlined below.

6.4.1 Free Earth Support Method

This method is based on the assumption that the shoring wall is embedded far enough to assure stability, but that the available passive resistance is incapable of restraining the shoring wall sufficiently to induce negative moment in the wall (i.e., there is no reversal of moment below excavation subgrade). The theoretical embedment required for stability is determined by statics. The theoretical depth of embedment required is determined by summing moments due to all pressures acting on the shoring wall about the bracing level. The embedment depth is adjusted until the sum of the moments about the bracing level is zero. Moments and shears in the shoring wall and the bracing reaction may be computed after the embedment depth is determined.



6.4.2 Fixed Earth Support Method

This method is based on the assumption that the shoring wall is embedded sufficiently to provide effective “fixity” at the bottom of the shoring wall (i.e., the deflected shape of the shoring wall is such that the wall reverses curvature over its embedded length and becomes vertical at its bottom). Unlike the Free Earth Support Method, moment reversal takes place over the embedded portion of the shoring wall. In comparison to the Free Earth Support Method, the embedment computed using the Fixed Earth Support Method would be longer; however, pile moment demand, pile deflection, and the bracing reaction will typically be reduced.

Hand calculating the required embedment depth for the Fixed Earth Support Method is not a trivial matter. However, through the use of commonly available structural analysis software, determining the depth of embedment required to produce the appropriate deflected shape of the shoring wall (i.e., effective fixity) is just a matter of iterating the depth of embedment. As for the Free Earth Support Method, moments and shears in the pile, and the bracing reaction may be computed after the theoretical embedment depth is determined.

6.4.3 Factor of Safety for Shoring Wall Embedment Depth

A factor of safety for the shoring wall embedment depth must be provided when either the Free Earth Support Method or Fixed Earth Support Method is used. When the theoretical embedment depth is computed based on the “unreduced” passive resistance (factor of safety equal to 1.0), this theoretical embedment depth shall be increased by a minimum of 40% to determine the design embedment depth (i.e. minimum factor of safety on theoretical embedment depth of 1.4). (This method should be used with caution when stiff to hard clays provide passive resistance, because the computed embedment depth may be unrealistically short.)

Embedment depths computed based on passive resistance that has been divided by a factor of safety of 2.0 will also be acceptable, provided that the resulting embedment depth is not significantly less than that computed using the nominal 40% increase in embedment depth discussed above.

See Section 6.8.1 for minimum embedment depths.

In Appendix B, Example 6.2 illustrates the Free Earth Support Method and Example 6.3 illustrates the Fixed Earth Support Method for the same excavation geometry in the same soil conditions for comparison purposes.

6.5 ANALYSIS OF WALLS WITH MULTIPLE LEVELS OF BRACING

6.5.1 Embedment Depth

The required depth of penetration for a shoring wall supported by two or more levels of bracing shall be determined by one of the following methods (See Section 6.8.1 for minimum embedment depths.):



1. The theoretical embedment may be calculated by balancing moments due to all soil, hydrostatic, lateral surcharge, and “unreduced” passive pressures (factor of safety equal to 1.0) acting below the lowest bracing level about the lowest bracing level. The moment capacity of the shoring wall shall be conservatively neglected in this analysis. The depth of penetration is adjusted until the sum of the moments equals zero. The computed theoretical embedment depth shall be increased by a minimum of 40% to determine the design embedment depth. (This method should be used with caution when stiff to hard clays provide passive resistance, because the computed embedment depth may be unrealistically short.)
2. The embedment depth may be computed by summing moments as noted above, using passive resistance values that have been reduced by dividing them by a factor of safety of 2.0. No increase in embedment is required when this method is used. This method will be acceptable provided that the resulting embedment depth is not significantly less than that computed using the nominal 40% increase in embedment depth discussed above.

6.5.2 Analysis of Shoring Wall

Moments and shears in the shoring wall shall be computed using beam analysis, assuming that the shoring wall is hinged at all bracing levels except the uppermost. Moments may be reduced to 80% of their computed values for design to account for wall continuity over the bracing locations.

Analysis of the portion of the shoring wall below the lowest bracing level shall be based on statics, including a consideration of all loads acting on the embedded portion of the shoring wall. A fictitious support at or below subgrade shall not be assumed for analysis purposes.

No redistribution of loads or reduction in the demand on the shoring wall due to soil arching shall be assumed.

6.5.3 Determination of Bracing Loads

Bracing loads shall be determined by beam analysis assuming that the shoring wall is hinged at all the bracing levels except the uppermost.

The load on the lowest bracing level shall be determined by statics, including a consideration of all loads acting on the embedded portion of the shoring wall. A fictitious support at or below subgrade shall not be assumed for analysis purposes.

6.6 ANALYSIS OF BRACING SYSTEMS

Unit (per foot) reactions at each bracing level are determined during the analysis of the shoring wall. For shoring walls with soldier piles (e.g., soldier pile and lagging walls, deep soil mix walls, and secant walls) point loads from each pile are computed by multiplying the pile spacing by the unit bracing reactions. Bracing loads for sheet piling may be assumed as a horizontal uniform load equal to the unit reactions.



Internal (cross-lot) bracing systems consisting of wales and struts shall be designed to resist the computed bracing loads. Moments, shears and axial loads in the bracing members shall be computed using standard methods of structural analysis.

Tieback or deadman systems that are used to restrain the shoring walls shall be designed to resist the computed bracing loads.

No redistribution of loads or reduction in the demand on bracing elements due to soil arching shall be assumed.

6.7 LAGGING ANALYSIS

Lagging may be designed for a load equal to 60% of the shoring design load (soil and surcharge pressures) to account for soil arching. The lagging members shall be designed as horizontal beams spanning between soldier piles.

In cases where soil arching cannot develop, reduced lagging loads shall not be considered.

Tabulated lagging thicknesses (such as those presented in Table 10-2 of the Caltrans *Trenching and Shoring Manual*) shall not be utilized.

6.8 GENERAL SHORING REQUIREMENTS

6.8.1 Minimum Embedment Depth

Computed embedment depths shall be compared with the following minimum values. In cases where the computed embedment depth is less than that specified below, the minimum embedment depth specified below shall be utilized:

- Cantilever walls: Embedment depth shall not be less than the height of the retained cut.
- Braced walls less than 20 feet high: Embedment depth shall not be less than 6 feet.
- Braced walls 20 feet high or more: Embedment depth shall not be less than 8 feet.

6.8.2 Secondary Bracing

Primary elements of the shoring system shall be provided with secondary bracing as required for stability. The secondary bracing elements shall be designed for an axial load equal to 3% of the axial load in the braced member.

6.8.3 Connections

Connections between the various elements of the shoring system shall be designed for tension and shear loads equal to at least 10% of the design compression load transferred through the connection. If the actual shear or tension at a connection is larger than this 10% value then the actual shear or tension load shall be utilized for design.



6.8.4 Stiffeners

Stiffeners shall be provided at shoring member connections when required by the provisions of Chapter K of the AISC, *ASD*.

6.9 SHORING DEFLECTION AND SETTLEMENT

All shoring designs within the Railroad Zone of Influence shall include an estimate of shoring deflection and retained earth settlement. Maximum permissible deflection shall enable the horizontal and vertical movement of the track to be limited to the requirements of Section 9.2. The amount of settlement that occurs will depend upon the soil type, the size of the excavation, the construction methods and quality of workmanship, and the design of the shoring system (including the stiffness of the shoring wall and bracing systems).

Elastic analyses of the shoring system should be performed for the various stages of support installation and removal in order to estimate lateral shoring deflection, which should then be used to make settlement estimates.



7.0 MATERIAL PROPERTIES AND ALLOWABLE STRESSES

The following examples are provided in Appendix B:

- Example 7.1 Wide Flange Wale Design
- Example 7.2 Pipe Strut Design
- Example 7.3 Shoring Wall Design
- Example 7.4 Wood Lagging Design

7.1 STEEL

Steel may be used material, provided that is free from any strength impairing defects.

7.1.1 *Structural Steel*

Allowable stresses for steel shall conform to the AISC, Steel Construction Manual - Allowable Stress Design (ASD), thirteenth edition, 2005, with the following additional constraints for struts:

- Slenderness ratio (L/r) shall not exceed 120.
- Axial stress shall not exceed 12 ksi.

No overstress shall be permitted.

Structural steel for which mill certificates are not available (unidentified steel) shall be designed for allowable stresses no greater than those allowed for ASTM A36 steel.

Bolted and welded connections shall be designed in accordance with the provisions of the AISC, ASD.

7.1.2 *Steel Sheet Piling*

The maximum allowable flexural stress in sheet piling shall not exceed 65% of the yield strength of the steel.

7.1.3 *Prestress Strand or Rod*

If prestress strands or rod are used as tieback tendons or as tie rods to a deadman, the allowable working stress shall not exceed 40% of the guaranteed ultimate tensile strength (GUTS).

If the strands or rod are used for purposes other than those specified above, the allowable working stress shall not exceed 60% of GUTS.

The shoring designer shall evaluate the potential effects of corrosion on strands and rods. Corrosion protection suitable for the installation environment and anticipated service life shall be provided.



7.1.4 Wire Rope Cable

The allowable working load for wire rope shall be no greater than 25% of the rated breaking strength.

If wire rope connectors with an efficiency less than 100% are used, the allowable working load shall be taken as no greater than 25% of the rated breaking strength multiplied by the efficiency of the connectors.

Wire rope used as a structural element for more than 30 days shall be galvanized.

7.2 CONCRETE

Reinforced and plain (unreinforced) concrete shall be designed using the Strength Design Method in accordance with ACI 318. No stress increases or load factor reductions shall be allowed.

7.3 WOOD

All wood shoring elements shall be Douglas Fir, No. 2 or better.

All wood that will remain in place permanently shall be pressure treated for ground contact use.

Allowable stresses shall be as follows:

Compression perpendicular to the grain = 450 psi

Compression parallel to the grain = $480,000/(L/d)^2 \leq 1600$ psi, where

L = unbraced length of member

d = lesser cross-sectional dimension of member

(L and d to have consistent units)

Flexural stress = 1700 psi

(reduced to 1,500 psi for members with a nominal depth of 8 inches or less)

Horizontal shear = 140 psi

7.4 OTHER MATERIALS

Allowable stresses for materials other than steel, concrete, and wood will be reviewed by SCRRRA on a case-by-case basis. Typically, industry-accepted allowable stresses or load factors (with no overstress allowances) will be acceptable.



8.0 SPECIAL CONDITIONS

8.1 SEALED SHORING

Under certain conditions, excavation below the groundwater table will require that a sealed shoring system be utilized. Examples of situations where sealed shoring is needed include, but are not limited to:

- Excavations in permeable soils where dewatering is infeasible or where the quantity of water to be handled and disposed of would be excessive.
- Locations where the groundwater is contaminated.
- Locations where dewatering would result in unacceptable settlement of the surrounding area.

Relatively watertight shoring is most commonly provided using interlocked sheet piling or diaphragm walls.

Where possible, groundwater flow around the bottom of the shoring wall should be prevented by extending the wall into an underlying low permeability soil layer (such as a clay layer). If a low permeability cut off layer is not present, or if it is at such a great depth that penetrating it is not feasible or cost effective, a tremie concrete or grouted seal slab should be considered for the base of the excavation.

In cases where a positive bottom seal is not provided, the potential for piping must be evaluated. See Section 8.3.

8.2 DEWATERING

Dewatering can be an effective means of reducing shoring loading and improving shoring stability and constructability. In some cases, it may also be required to allow construction of proposed project elements.

In cases where dewatering is not precluded by other factors (see Section 8.1), SCRRRA will consider allowing dewatering, provided that it won't cause problematic track settlement. The potential for problematic track settlement to occur will be a function of the site soil profile and the depth to which the site needs to be dewatered. Track settlement in excess of that specified in Section 9.1 may be acceptable if it can be shown that differential track settlements resulting from dewatering will be minimal (i.e., settlements will occur over a broad area). Engineering calculations demonstrating that excessive differential settlement will not occur will be required.

In cases where the performance of the temporary shoring system depends upon the functionality of the dewatering system, the dewatering system shall be fail-safe. Elements such as an uninterrupted power supply, back-up pumps, and failure alarm signals will be required to guarantee that the dewatering system will never shut down for a period of time that could compromise the stability of the shored excavation.

Dewatering system design shall be performed by a Civil Engineer registered in the State of California with previous experience in the design of the specific type of dewatering system being



proposed. Removed water shall not be drained along the tracks, but shall be drained off the Right-of-Way in accordance with environmental restrictions.

8.3 BOTTOM STABILITY

8.3.1 Piping

For excavations in pervious materials, the possibility of piping must be evaluated. Piping occurs when an unbalanced hydrostatic head causes large upward seepage pressures in the soil at and below the bottom of the excavation. The upward seepage pressure reduces the effective weight of the soil below the bottom of the excavation. As a result, the ability of the soil to laterally support the embedded portion of the shoring wall (i.e., passive resistance) is reduced. In the extreme, a quick condition can develop at the bottom of the excavation and large quantities of soil can be transported rapidly from outside to inside the excavation, thereby causing large ground settlements, and possibly even shoring system collapse.

Piping can be controlled by dewatering outside the shoring walls (where allowed) or by making the shoring walls deeper in order to reduce the upward hydraulic gradient. Alternatively, a tremie or grouted slab can be used as a bottom seal.

The potential for piping may be evaluated using published procedures (see the Caltrans *Trenching and Shoring Manual*). The minimum acceptable factor of safety against piping shall be 1.5. Additionally, a reduction in the available passive resistance due to upward seepage pressures shall be taken as appropriate.

8.3.2 Bottom Heave

In cases where excavations are made in soft (and sometimes medium) clays the potential for bottom heave must be evaluated. Bottom heave occurs when the depth of excavation is sufficient to cause upward movement of material in the bottom of the excavation and corresponding downward displacement of material surrounding the excavation. Heave can result in excessive settlement of the ground retained by the shoring system, and distress or failure of the shoring.

The possibility for heave should be evaluated further in cases when the Stability Number (N_o) exceeds 4, where:

$$N_o = (\gamma H + q) / c, \text{ and}$$

γ = unit weight of soil
 H = depth of excavation
 q = vertical surcharge pressure
 c = cohesive strength of soil

When N_o exceeds 4, the factor of safety against bottom heave should be computed using procedures outlined in the Caltrans *Trenching and Shoring Manual*. The minimum acceptable factor of safety against bottom heave shall be 1.5.



8.4 GLOBAL STABILITY

Typical shoring applications may not require global slope stability analyses. The Engineer in Responsible Charge shall determine if global stability calculations are warranted. However, SCRRA reserves the right to require global stability calculations at their sole discretion.

If applicable and/or required by SCRRA, temporary shoring systems and sloped excavations shall be demonstrated to be safe using limit equilibrium analyses with appropriate potential failure surfaces. Slope stability analyses shall consider the presence of Cooper's E-80 live loading on active tracks.

The minimum factor of safety against failure of the whole, or any portion of, shored or sloped cuts shall be 1.5.

8.5 TIEBACKS

Tiebacks will be allowed only where necessary and where Right-of-Way limits are sufficient. If tiebacks are permitted they must be installed using a method in which the drilled holes for the tiebacks will be stable and open at all times. In some soil types, this will necessitate fully cased holes beneath active tracks. Tiebacks shall be located a minimum of 5 feet below top of rail.

Tiebacks shall be designed in accordance with the procedures and criteria outlined in the Post-Tensioning Institute (PTI), *Recommendations for Prestressed Rock and Soil Anchors*, with the exception that the allowable stresses for the tieback tendons shall be limited to those values specified in Section 7.1 of these Guidelines. A minimum factor of safety of 2.0 shall be used.

All tiebacks shall be load tested. Procedures and acceptance criteria for performance and proof testing shall conform to those given in the Post-Tensioning Institute (PTI), *Recommendations for Prestressed Rock and Soil Anchors*. The first 3 tiebacks installed and a minimum of 10% of the remaining tiebacks shall be performance tested. All remaining anchors shall be proof tested.

When tiebacks are bonded in fine-grained soils, creep testing shall be done in lieu of performance testing. Creep testing procedures and acceptance criteria shall conform to those given for temporary anchors in the Post-Tensioning Institute (PTI), *Recommendations for Prestressed Rock and Soil Anchors*.

In addition to the PTI *Recommendations for Prestressed Rock and Soil Anchors*, the designer may also reference FHWA Geotechnical Engineering Circular No. 4, *Ground Anchors and Anchored Systems*, FHWA-IF-99-015.

Tiebacks shall be locked-off at a minimum of 75% and a maximum of 100% of their design load.

8.6 DEADMEN

Under the appropriate conditions SCRRA may allow temporary shoring walls to be supported using deadmen located on the opposite side of the tracks from the shored excavation. The proposed location(s) for deadman anchorage will require review and acceptance by SCRRA



and any Third Party property owners as appropriate. Tie rods to deadmen shall be a minimum of 5 feet below top of rail.

Deadman anchorage may be provided by soldier piles, sheet piling, or concrete blocks or walls. Deadman anchors shall be designed in accordance with the procedures outlined in the Caltrans *Trenching and Shoring Manual*.

Deadman anchors shall be designed to provide a minimum factor of safety of 2.0 against failure.

In order to minimize the deflection of the shoring, deadman anchors shall be prestressed to removed the slack in the system and to mobilize the passive resistance. A portion of the final design load shall be locked off.

Tie rods that pass under the tracks must be electrically isolated from the track. Details of proposed system of electrical isolation shall be submitted for review.



9.0 TRACK MONITORING

9.1 PURPOSE

SCRRA requires monitoring of the excavation, temporary shoring system and adjacent track(s) throughout the duration of shoring installation, excavation, construction, removal and backfill. The monitoring procedures specified below are intended to confirm that shoring systems are performing in a satisfactory manner and to identify locations of excessive ground movement so that they can be controlled and corrected in a timely manner.

9.2 LIMITATION ON TRACK MOVEMENT

SCRRA requires that track settlement or track heave associated with all aspects of shoring and excavation shall not exceed $\frac{1}{2}$ inch vertical change. Track movement shall not exceed $\frac{1}{2}$ inch horizontal change due to temporary shoring and excavation. Track resurfacing or other remedial measures may be required if these limits are exceeded.

9.3 MINIMUM MONITORING REQUIREMENTS

The excavation and temporary shoring system shall be visually inspected at least daily by qualified Contractor personnel to check for obvious movements or changes that were unplanned or that may be detrimental to railroad operations or safety. Visual monitoring should be performed more often during the performance of critical activities, such as excavation or foundation installation immediately adjacent to shoring or after moderate to severe rain events.

SCRRA requires that tracks adjacent to excavations within the Railroad Zone of Influence be monitored for movement and settlement. At a minimum, track monitoring shall consist of the following:

- Survey points shall be established along all tracks for which the excavation is within the Railroad Zone of Influence. The maximum spacing and minimum extent of these points shall be as shown on Figure 9-1. A minimum of three (3) control points shall be established in areas that will not be subject to possible disturbance due to construction activities or railroad operations.
- The surveying method utilized for track monitoring shall be accurate to $\pm 1/8$ inch and shall comply with the railroad surveying requirements in the SCRRA Design Criteria Manual.
- The horizontal coordinates and elevation of both rails shall be measured at each survey point location in accordance with the following schedule:
 - A baseline reading of coordinates and elevations shall be taken prior to installation of any elements of the shoring system. In cases where track maintenance activities are performed to correct movements, a new baseline shall be established and its relationship to the previous baseline documented.



- Readings shall be taken twice weekly from the time at which shoring installation commences until shoring removal is completed. Supplemental readings may be required if excessive or unanticipated settlements are recorded.
- Readings shall continue on a once weekly basis for a minimum of four weeks after shoring removal has been completed.

The monitoring requirements outlined above may be relaxed or waived on a project-specific basis at the sole discretion of SCRRA.

Survey readings and reduced survey data shall be provided to SCRRA immediately following each survey. Survey data and comparison to previous and baseline data should be provided on a form similar to that shown in Figure 9-3. SCRRA shall be specifically notified of any change in elevation of ¼ inch or greater. It is likely that SCRRA will require supplemental monitoring in the case of vertical movements in excess of ¼ inch.

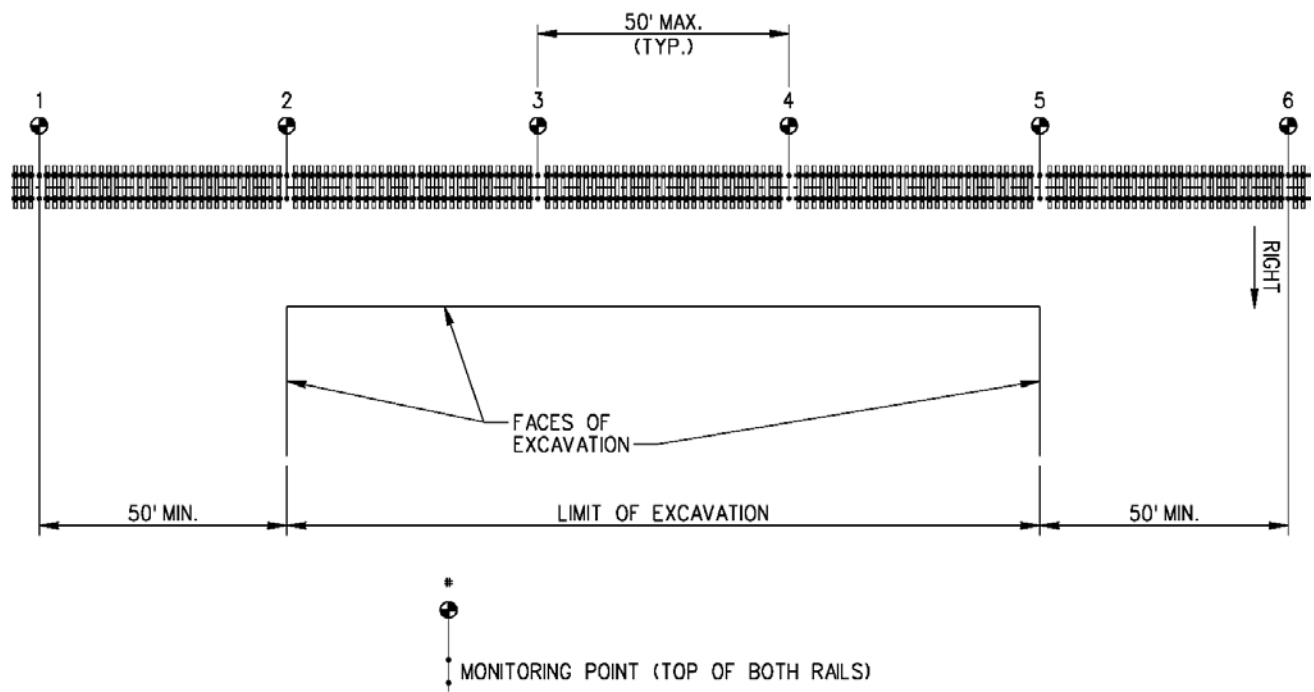

Figure 9-1: Minimum Monitoring Requirements

9.4 SUPPLEMENTAL MONITORING

Supplemental monitoring may be required by SCRRA. Typically, supplemental monitoring will be required when any vertical change of ¼ inch or greater is measured by survey readings of static track elevation. Supplemental monitoring consists of the following:

- More frequent survey measurements of static top of rail elevations and coordinates.
- Measurement of rail movements and cross-slope under load.



Figure 9-2 depicts a method of measuring rail movements under load. Loaded rail movement measurements may be performed as follows:

- At each survey point, place a 20d nail vertically into the ballast crib between ties with the head end directly under the base of each rail, taking care to place the nail head in direct contact with the rail.
- Allow a typical commuter or freight train to pass through the location at normal speed.
- Return to each survey point and measure and record the distance from the base of each rail down to the top of the nail head using a tape or gauge to the nearest 1/8 inch.

Provide SCRRA with survey readings, reduced survey data, loaded measurements and reduced loaded measurement data immediately following the survey. Loaded measurement data and comparison to previous and baseline data should be provided on a form similar to that shown in Figure 9-4.

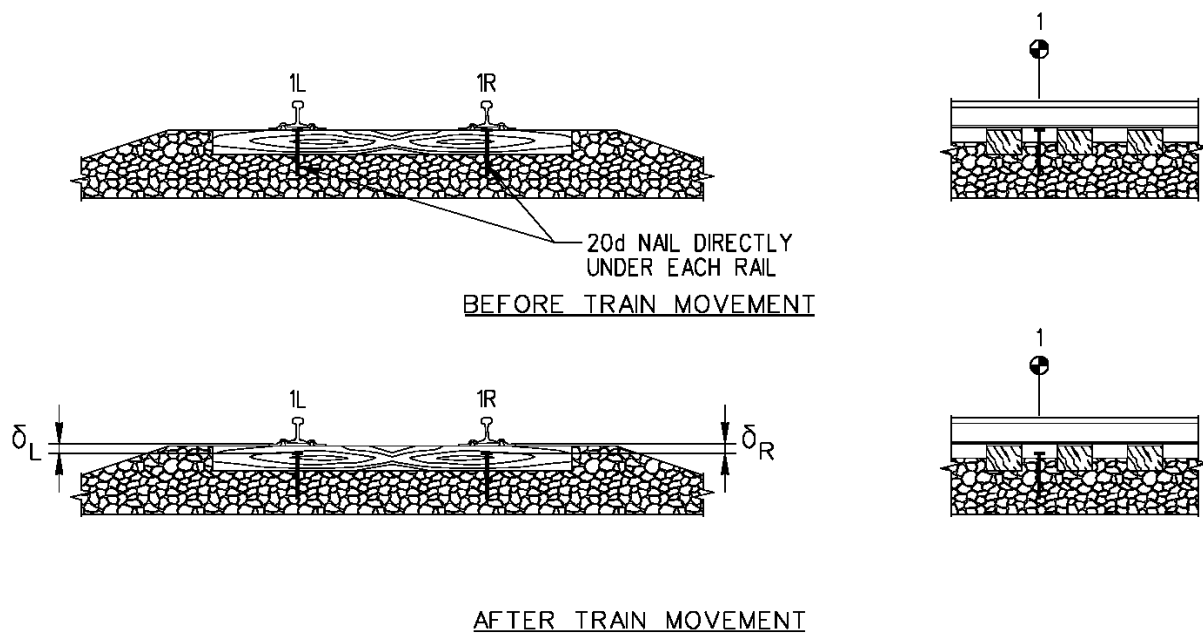

Figure 9-2: Method of Loaded Measurement



Point No.	Station	Surveyed Static T/Rail Elevations			Static T/Rail Change from Previous			Static T/Rail Change from Baseline		
		E_L	E_R	E_{avg}	ΔE_L	ΔE_R	ΔE_{avg}	ΔE_{Li}	ΔE_{Ri}	ΔE_{avgi}
1	100+00									
2	100+50									
3	101+00									
.	.									
.	.									
.	.									
n										

Figure 9-3: Reporting Static Top of Rail Survey Results

Point No.	Station	Measured Loaded Movements			Cross-Slope $\delta_{CS} = \delta_L - \delta_R $	Loaded Change from Previous			Cross-Slope $\Delta\delta_{CS} = \Delta\delta_L - \Delta\delta_R $	Loaded Change from Baseline			Cross-Slope $\Delta\delta_{CSi} = \Delta\delta_{Li} - \Delta\delta_{Ri} $
		δ_L	Total δ_R	δ_{avg}		$\Delta\delta_L$	Total $\Delta\delta_R$	$\Delta\delta_{avg}$		$\Delta\delta_{Li}$	Total $\Delta\delta_{Ri}$	$\Delta\delta_{avgi}$	
1	100+00												
2	100+50												
3	101+00												
.	.												
.	.												
.	.												
n													

Figure 9-4: Reporting Loaded Measurement Results



9.5 SPECIAL MONITORING

SCRRA reserves the right to require that special monitoring be done for large, atypical, or long-lived shoring projects. Special monitoring may include the use of inclinometers, piezometers, tiltmeters, or other types of monitoring instrumentation. SCRRA will address this issue on a project-specific basis.

9.6 ACCESS AND FLAGGING

Access and flagging for establishing and reading survey points and monitoring instrumentation shall be coordinated with SCRRA.



10.0 SUBMITTAL REQUIREMENTS

10.1 GENERAL

All drawings and calculations for temporary shoring shall be prepared, sealed and signed by a Professional Engineer (civil or structural) currently licensed in the State of California who has previous experience in the design of temporary shoring systems of the type being submitted (preferably 10 years). Preferably, temporary shoring systems will be designed by a team composed of a railroad civil engineer who is experienced, knowledgeable and competent in design, construction, operations and maintenance parameters for commuter/passenger and freight railroad systems, and a licensed civil or structural engineer who is experienced, knowledgeable and competent in the design and construction of shored excavations adjacent to railroad tracks.

The designer will be responsible for the accuracy of all controlling dimensions as well as the selection of soil design values that accurately reflect the actual field conditions. No shoring installation or excavation within the Railroad Zone of Influence will be allowed until the drawings and calculations are reviewed and accepted by SCRRA.

Submittal of forms, drawings and calculations shall be provided to SCRRA for review in electronic format transmitted by email, ftp or mail (with CD-R or DVD-R properly labeled). Files shall be Adobe PDF compatible with Version 6. Each separate document shall be a separate PDF file (drawings, specifications, calculations, forms, etc.). Files shall be named with a letter indicating the project phase (d – design, c – construction), abbreviated SCRRA subdivision and milepost, and a shortened name describing the contents of the file (e.g. – d_la34511_calcs.pdf).

All submittals, design calculations, specifications and drawings shall be prepared in accordance with a QA/QC process. The QA/QC process may follow the established program of SCRRA, Public Agency, Engineer in Responsible Charge firm, or Contractor. At a minimum, the QA/QC process must consist of an independent check of design calculations and an independent QC review of the drawings and specifications prior to submittal to SCRRA by qualified individuals. Documentation of the QA/QC process, including names and contact information of independent reviewers, shall be made available to SCRRA at their request.

A minimum of 30 calendar days should be allowed for SCRRA's review, provided that all required submittal materials are included and properly identified.

10.2 EXCLUSIVE TRACK WINDOWS

Exclusive Track Windows are rare and limited to specific work activities over a small defined area for a short time. Procedures for requesting an Exclusive Track Window are as follows:

Exclusive Track Window Request Procedure

1. Contact SCRRA Office of Rail Corridor Crossings and Encroachments a minimum of 90 days prior to the proposed date of excavation for coordination.



2. Complete and submit the Design Exception Form provided in Appendix C a minimum of 60 days prior to the proposed date of excavation. It is imperative that the following specific information be included on the form or as an attachment:
 - a. Exact location of the proposed work (attach maps and/or figures) and include the following:
 - i. Railroad stationing and milepost (SCRRA will assist in providing this information)
 - ii. North arrow
 - b. Complete description of the proposed work
 - c. Proposed date of work
 - d. Proposed duration of Exclusive Track Window required
 - e. Description of alternates not requiring an Exclusive Track Window and brief evaluation to show that any other alternate is not practical
 - f. SSWP
3. SCRRA will review the request and return a decision within 30 days.
4. If the Exclusive Track Window request is approved by SCRRA, the applicant agrees to follow all conditions imposed by SCRRA and provide compensation for all costs incurred by SCRRA associated with the Exclusive Track Window and work on SCRRA Right-of-Way. The SSWP must be accepted by SCRRA prior to proceeding with any work.
5. Special pre-construction meeting, contingency plan(s), extra equipment and extra work crews may be required by SCRRA.

10.3 EXCEPTIONS, WAIVERS AND VARIANCES

Procedures for requesting an exception, waiver and/or variance to the requirements of these Guidelines are as follows:

Variance Request Procedure

1. For projects under design, variance requests shall be submitted at the Concept or 30% review levels for consideration by SCRRA. Concept level variance requests are preferred. Design should not be advanced to the 60% level prior to receiving a decision on a variance request.
2. Complete the Design Exception Form provided in Appendix C. Submit the variance request to SCRRA Office of Rail Corridor Crossings and Encroachments. This shall be a separate submittal from any design review submittal. The request should be signed and sealed by the Engineer in Responsible Charge. It is imperative that the following specific information be included on the form or as an attachment:
 - a. Exact location of the proposed work (attach maps and/or figures) and include the following:
 - i. Railroad stationing and milepost (SCRRA will assist in providing this information)
 - ii. North arrow
 - b. Identify the exact provision of the Guidelines for which the exception, waiver or variance is requested
 - c. Complete description of the proposed work
 - d. Proposed limits of excavation, plan area and depth
 - e. Proposed type(s) of shoring including hand railing or other means of protection for track workers and operations personnel working adjacent to track
 - f. Proof of concept drawings and calculations



- g. Proposed duration of Work Windows required for installation and removal of shoring systems
 - h. Proposed duration of shoring system and means for ensuring track is not displaced while system is in place
 - i. Description of alternates that conform to these Guidelines and brief evaluation to show that any other alternate is not practical
3. SCRRA will review the request and return a decision within 60 days.
4. If the variance request is accepted by SCRRA, the applicant agrees to follow all conditions imposed by SCRRA. For shoring within Zone 2, complete owner-designed shoring and details per Section 3.1 shall be included in the plans at the 90% level. Design conditions and requirements for any Contractor-designed alternate shoring system shall be included in the plans and specifications. SSWP shall be prepared and submitted by the Contractor a minimum of 30 days prior to the proposed date of excavation.
5. For projects already under construction, contact SCRRA a minimum of 120 days prior to the proposed date of excavation for coordination. Variances will not be considered with advance notice less than 90 days. The variance request shall be submitted along with the Design Exception Form to SCRRA Office of Rail Corridor Crossings and Encroachments.

10.4 DRAWINGS

The shoring drawings must be complete and shall accurately describe the nature of the work. Drawings shall be to-scale.

At a minimum the shoring drawings shall include the following:

- Plan view that includes the following information and meets the following criteria:
 - Railroad stationing and milepost (SCRRA will assist in providing this information)
 - North arrow
 - All pertinent topographic information
 - All Operating System elements and facilities
 - All overhead and underground utilities
 - All of the proposed excavations and distances from centerline of the track(s) to the face of the excavation and temporary shoring at relevant locations
 - Proposed types and locations of equipment used to install the temporary shoring
 - The drawing shall be in U.S. units with a scale no less than 1"=10'. Acceptable scales include 1"=10', 1/8"=1'-0", and 1/4"=1'-0".
- Section view normal to the track(s) showing the temporary shoring system relative to the centerline of the track(s). The section shall show elevations of the track(s), the existing ground surface, excavation lines at each stage as applicable, and bracing elements. Protective dividers, fences, handrail and walkway shall be shown as applicable. Minimum horizontal clearances from centerline of track to nearest obstruction at top of rail elevation and above shall be provided. The section shall also show shoring wall embedment depth and approximate groundwater depth.
- Arrangement and sizes of shoring elements and details of all connections.



- Specifications for materials and requirements for shoring fabrication and installation.
- Construction sequence(s) detailing all steps in the shoring installation, excavation, and shoring removal. Include and highlight those items requiring Work Windows.
- Track monitoring requirements (types, locations, reading schedule, etc.). See Section 9.0 for requirements.

10.5 DESIGN CALCULATIONS

Design calculations shall be provided for all elements of the shoring system.

The calculations shall consider each stage of excavation and support removal.

The calculations shall include estimates of shoring deflection, demonstrating that the proposed system will not cause excessive settlement of the tracks. See Section 9.2 for settlement limitations.

A summary of the soil parameters used in the design shall be included in the calculations, and the source reference for these parameters shall be identified and provided. Include a copy of the geotechnical report if available.

Input and output from computer programs used for analysis and design of temporary shoring shall be accompanied by hand calculations verifying the input and results. In cases where the analysis methods used by the program are not shown in the output, appropriate documentation of the program's calculations shall be provided.

10.6 DESIGN CHECKLIST

The shoring designer shall complete, seal and sign a copy of the Submittal Checklist included in Appendix A of these Guidelines. The completed checklist shall accompany the shoring submittal.

10.7 OTHER INFORMATION

In the event that all or part of the proposed shoring system consists of commercially available, prefabricated elements (e.g., a trench shield), the shoring submittal shall include complete design data for these elements, including data to show that the system is compatible with the geotechnical characteristics at the site and provides capacity to handle all anticipated loads.

10.8 SITE SPECIFIC WORK PLAN (SSWP)

The construction of all shoring and excavation work within the Basic Safety Envelope will require the Contractor to submit a Site Specific Work Plan (SSWP).

The SSWP shall:

- Contain a description of any proposed temporary changes to the Operating System.



- Describe the activities necessary to perform specific shoring work within the Basic Safety Envelope.
- Contain a schedule of the work, including a detailed schedule that indicates the expected hourly progress of each activity that has a duration of one hour or longer. The schedule shall include the time at which all activities planned under the SSWP will be completed.
- Show each activity and where and how it affects the normal operation on the Operating System. Activities that require Work Windows shall be specifically identified.
- Include all materials and equipment required to complete each activity in the SSWP within the allotted time period. Show anticipated locations where equipment may be placed, especially equipment that has the potential to foul the tracks.
- Include contingency plans for putting the Operating System back in operation in case of emergency or in case the Contractor fails to perform and complete the work on time. Contingency plans shall address the various stages of construction and may require redundant equipment and personnel.

The SSWP shall be submitted to SCRRRA a minimum of 30 days prior to the start of the work within the Basic Safety Envelope.

The Contractor's construction activities that impact the Operating System including tracks, signals, bridges, stations, and related facilities in active service shall be subject to the following requirements. These requirements shall be addressed in a SSWP:

- Contractor shall provide sufficient personnel, equipment, materials, and all other resources necessary to return the impacted facilities to full service upon the conclusion of the approved Work Window.
- Contractor shall perform the work expeditiously and continuously with no gaps or breaks in the work activities or substantive reductions in the labor force, equipment and materials necessary to construct, reconstruct or repair the impacted facility to the full service upon the conclusion of any Work Window.
- The size and scope of the impacted facilities within the Operating System (e.g., tracks or signal systems removed) shall not exceed the Contractor's capacity to conservatively return the impacted facility to the required level of service within the approved Work Window.
- The justification for removing both main tracks from service to the extent that Work Train, UPRR or BNSF freight, and rail bound construction equipment would be precluded from through moves for more than three (3) hours.
- Contractor shall take all appropriate and reasonable measures to perform work activities and tasks located outside the Operating System to effectively reduce the amount of time and effort required during any Work Window. These appropriate and reasonable



measures shall include, but not be limited to, pre-construction and pre-assembly of shoring systems (e.g., trench shields) and pre-staging of shoring materials.

- Backup or Emergency Plan: Contractor shall include in the SSWP backup and/or contingency plan(s) and the necessary resources (labor, equipment, materials, etc.) to assure SCRRA that all appropriate and reasonable measures are available for the return of the impacted facility to full service upon conclusion of any Work Window.
- When not in use, materials and equipment shall not be piled, stored, or parked closer than 25 feet horizontally from the centerline of the nearest operating track.

10.9 CONSTRUCTION VERIFICATION

The temporary shoring Engineer in Responsible Charge (or his/her authorized designee) shall inspect the as-built shoring system to verify that the system is constructed in accordance with the shoring plans that have been reviewed and accepted by SCRRA. The Engineer in Responsible Charge shall prepare a letter that shall be submitted to SCRRA confirming that the shoring system has been inspected and verified. Any field changes shall be listed in the letter and the effect of those changes shall be evaluated by the Engineer in Responsible Charge. Any deficiencies noted by the Engineer in Responsible Charge shall be corrected by the Contractor. Deficiencies and corrections shall be noted in the letter with verification of adequate correction by the Engineer in Responsible Charge.

The number of site visits and the stage or stages of construction at which they shall be performed will be specified by SCRRA as a condition of acceptance of the temporary shoring design. The intent will be to have the temporary shoring installation verified by the Engineer in Responsible Charge at critical construction stages.



Appendices

Appendix A	Submittal Checklists
Appendix B	Sample Calculations
Appendix C	SCRRA Design Exception Form



Appendix A – SUBMITTAL CHECKLISTS

DESIGN CHECKLIST

The shoring designer shall complete, seal, sign, and submit the enclosed Shoring Submittal Design Checklist with the shoring design submittal.

REVIEW CHECKLIST

The enclosed Shoring Submittal Review Checklist shall be utilized by SCRRRA staff or consultants to aid the review of shoring design submittals.



SCRRRA SHORING SUBMITTAL DESIGN CHECKLIST

Project Name/Location: _____
 Submittal Date: _____
 Shoring Design Firm: _____
 Contractor: _____

Item	Yes/No/NA	Explain if No or NA
Drawings – Checked, Signed & Sealed?		
1. Drawings to-scale?		
2. Plan view is oriented correctly and shows relative position of shoring/excavation and tracks, railroad stationing and mileposts, and all pertinent Operating System facilities (surface and underground)?		
3. Section normal to track(s) shows elevations of track(s), ground surface, excavation subgrade, bracing elements and horizontal clearances?		
4. Dimensions defining the arrangement of all elements of shoring system provided?		
5. Sizes of all shoring elements provided?		
6. All connections detailed?		
7. Specifications for all materials provided?		
8. Specifications and requirements for fabrication and installation provided?		
9. Construction sequence(s) detailing all steps in the shoring installation, excavation, planned installation equipment location and shoring removal provided?		
10. Track monitoring requirements specified?		
11. Impacts to existing drainage addressed?		
Design Calculations – Checked, Signed & Sealed?		
General:		
1. Design calculations provided for all elements of the shoring system?		
2. Calculations for all stages of excavation and support removal?		
3. Shoring designer has verified the accuracy, suitability, and applicability of the information and criteria outlined in the Excavation Support Guidelines for the specific application being designed?		
Loading:		
4. Soil loading (active and passive) developed in accordance with Section 4.2 of the Excavation Support Guidelines?		
5. Groundwater loading developed in accordance with Section 4.3 of the Excavation Support Guidelines?		
6. Surcharge loading (other than railroad surcharge) developed in accordance with Section 4.4 of the Excavation Support Guidelines?		
7. Seismic loading considered?		
8. Railroad live load surcharge developed in accordance with Section 5 of the Excavation Support Guidelines?		
9. All required loads considered in shoring analysis?		



SCRRA SHORING SUBMITTAL DESIGN CHECKLIST (CONTINUED)

Item	Yes/No/NA	Explain if No or NA
Analysis:		
10. Shoring wall analyzed in accordance with Section 6 of the Excavation Support Guidelines?		
11. Bracing loads determined in accordance with Section 6 of the Excavation Support Guidelines?		
12. Embedment depth of wall determined in accordance with Section 6 of the Excavation Support Guidelines?		
13. Bracing system analyzed in accordance with Section 6.6 of the Excavation Support Guidelines?		
14. Lagging analyzed in accordance with Section 6.7 of the Excavation Support Guidelines?		
15. Secondary bracing, connections, and stiffeners analyzed and provided in accordance with Section 6.8 of the Excavation Support Guidelines?		
16. Shoring deflection and settlement estimated in accordance with Section 6.9 of the Excavation Support Guidelines?		
Material Properties and Allowable Stresses:		
17. Material properties and allowable stresses in accordance with Section 7 of the Excavation Support Guidelines?		
Special Conditions:		
18. Is external dewatering proposed?		
a. If yes, has dewatering been accepted by SCRRA?		
b. If yes, has a settlement analysis (due to dewatering) been provided?		
19. Has the potential for piping been evaluated?		
20. Has potential for heave been evaluated?		
21. Has global stability of the shoring system been evaluated?		
22. Are tiebacks proposed?		
a. If yes, has SCRRA accepted their usage?		
b. If yes, are they designed and will they be tested in accordance with Section 8.5 of the Excavation Support Guidelines?		
23. Are deadmen proposed?		
a. If yes, has SCRRA accepted their usage?		
b. If yes, has third party approval been granted?		
c. If yes, are they designed in accordance with Section 8.6 of the Excavation Support Guidelines?		

Shoring Designer Signature

Print Name



SCRRRA SHORING SUBMITTAL REVIEW CHECKLIST

Project Name/Location: _____

Date: _____

Name of Reviewer: _____

Item	Yes/No/NA	Explain if No or NA
Drawings – Signed & Sealed?		
1. Drawings to-scale?		
2. Plan view is oriented correctly and shows relative position of shoring/excavation and tracks, railroad stationing and mileposts, and all pertinent Operating System facilities (surface and underground)?		
3. Section normal to track(s) shows elevations of track(s), ground surface, excavation subgrade, bracing elements and horizontal clearances?		
4. Dimensions defining the arrangement of all elements of shoring system provided?		
5. Sizes of all shoring elements provided?		
6. All connections detailed?		
7. Specifications for all materials provided?		
8. Specifications and requirements for fabrication and installation provided?		
9. Construction sequence(s) detailing all steps in the shoring installation, excavation, planned installation equipment location and shoring removal provided?		
10. Track monitoring requirements specified?		
11. Impacts to existing drainage addressed?		
Design Calculations – Signed & Sealed?		
General:		
1. Design calculations provided for all elements of the shoring system?		
2. Calculations for all stages of excavation and support removal?		
3. Shoring designer has verified the accuracy, suitability, and applicability of the information and criteria outlined in the Excavation Support Guidelines for the specific application being designed?		
Loading:		
4. Soil loading (active and passive) developed in accordance with Section 4.2 of the Excavation Support Guidelines?		
5. Groundwater loading developed in accordance with Section 4.3 of the Excavation Support Guidelines?		
6. Surcharge loading (other than railroad surcharge) developed in accordance with Section 4.4 of the Excavation Support Guidelines?		
7. Seismic loading considered?		
8. Railroad live load surcharge developed in accordance with Section 5 of the Excavation Support Guidelines?		
9. All required loads considered in shoring analysis?		



SCRRA SHORING SUBMITTAL REVIEW CHECKLIST (CONTINUED)

<u>Item</u>	<u>Yes/No/NA</u>	<u>Explain if No or NA</u>
Analysis:		
10. Shoring wall analyzed in accordance with Section 6 of the Shoring Guidelines?		
11. Bracing loads determined in accordance with Section 6 of the Shoring Guidelines?		
12. Embedment depth of wall determined in accordance with Section 6 of the Shoring Guidelines?		
13. Bracing system analyzed in accordance with Section 6.6 of the Shoring Guidelines?		
14. Lagging analyzed in accordance with Section 6.7 of the Shoring Guidelines?		
15. Secondary bracing, connections, and stiffeners analyzed and provided in accordance with Section 6.8 of the Shoring Guidelines?		
16. Shoring deflection and settlement estimated in accordance with Section 6.9 of the Shoring Guidelines?		
Material Properties and Allowable Stresses:		
17. Material properties and allowable stresses in accordance with Section 7 of the Shoring Guidelines?		
Special Conditions:		
18. Is external dewatering proposed?		
a. If yes, has dewatering been accepted by SCRRA?		
b. If yes, has a settlement analysis (due to dewatering) been provided?		
19. Has the potential for piping been evaluated?		
20. Has potential for heave been evaluated?		
21. Has global stability of the shoring system been evaluated?		
22. Are tiebacks proposed?		
a. If yes, has SCRRA accepted their usage?		
b. If yes, are they designed and will they be tested in accordance with Section 8.5 of the Shoring Guidelines?		
23. Are deadmen proposed?		
a. If yes, has SCRRA accepted their usage?		
b. If yes, has third party approval been granted?		
c. If yes, are they designed in accordance with Section 8.6 of the Shoring Guidelines?		

Reviewer's Signature

Print Name

Finding:

- No Exceptions Taken
- Make Corrections Noted
- Amend and Resubmit



Appendix B – SAMPLE CALCULATIONS

Section 4 – Loading On Shoring Systems

- Example 4.1 Develop an Active Soil Pressure Diagram
- Example 4.2 Develop an Apparent Pressure Diagram
- Example 4.3 Determine Passive Resistance (Cohesionless Soil)
- Example 4.4 Determine Passive Resistance (Cohesion Soil)

Section 5 – Railroad Live Load Surcharge

- Example 5.1 Railroad Live Load Surcharge from Two Tracks
- Example 5.2 Railroad Live Load Surcharge from Three Tracks
- Example 5.3 “Simplified” Railroad Live Load Surcharge

Section 6 – Shoring Analysis Methodologies

- Example 6.1 Cantilever Soldier Pile and Lagging Shoring Wall
- Example 6.2 Sheet Pile Shoring Wall, One Level of Bracing (Free Earth Support Method)
- Example 6.3 Sheet Pile Shoring Wall, One Level of Bracing (Fixed Earth Support Method)
- Example 6.4 Analysis of a Diaphragm Shoring Wall with Three Levels of Bracing

Section 7 – Material Properties and Allowable Stresses

- Example 7.1 Wide Flange Wale Design
- Example 7.2 Pipe Strut Design
- Example 7.3 Shoring Wall Design
- Example 7.4 Wood Lagging Design



EXAMPLE 4.1 – DEVELOP AN ACTIVE SOIL PRESSURE DIAGRAM

PROBLEM:

DEVELOP ACTIVE SOIL PRESSURES FOR THE FOLLOWING SOIL PROFILE.

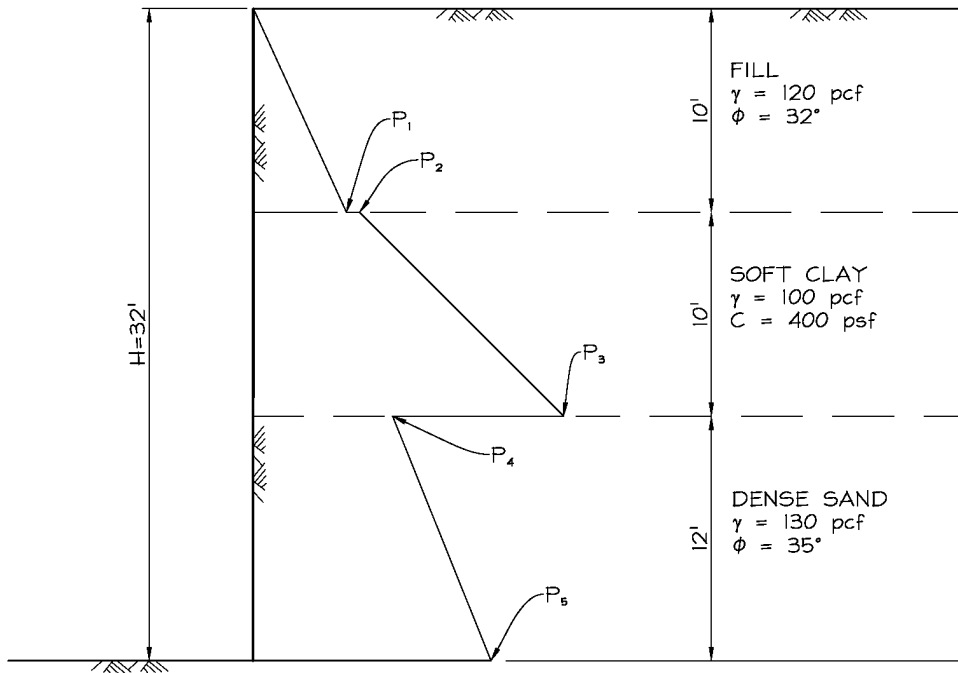

SOLUTION:

USING RANKINE THEORY -

$$K_{A,FILL} = \tan^2(45^\circ - \phi_{FILL}/2) = \tan^2(45^\circ - 32^\circ/2) = \underline{0.31}$$

$$K_{A,DENSE\ SAND} = \tan^2(45^\circ - \phi_{DENSE\ SAND}/2) = \tan^2(45^\circ - 35^\circ/2) = \underline{0.27}$$

COMPUTE ACTIVE PRESSURES -

$$P_1 = K_{A,FILL}(\gamma_{FILL})(10') = 0.31(120)(10) = \underline{372\ psf}$$

$$P_2 = \gamma_{FILL}(10') - 2C = 120(10) - 2(400) = \underline{400\ psf}$$

$$P_3 = P_2 + \gamma_{SOFT\ CLAY}(10') = 400 + 100(10) = \underline{1400\ psf}$$

$$P_4 = K_{A,DENSE\ SAND}[(\gamma_{FILL})(10') + (\gamma_{SOFT\ CLAY})(10')] = 0.27[(120)(10) + (100)(10)] = \underline{594\ psf}$$

$$P_5 = P_4 + K_{A,DENSE\ SAND}[(\gamma_{DENSE\ SAND})(12')] = 594 + 0.27(130)(12) = \underline{1015\ psf}$$



EXAMPLE 4.2 – DEVELOP AN APPARENT PRESSURE DIAGRAM

PROBLEM:

DEVELOP AN APPARENT PRESSURE DIAGRAM FOR THE SOIL PROFILE GIVEN IN EXAMPLE 4.1.

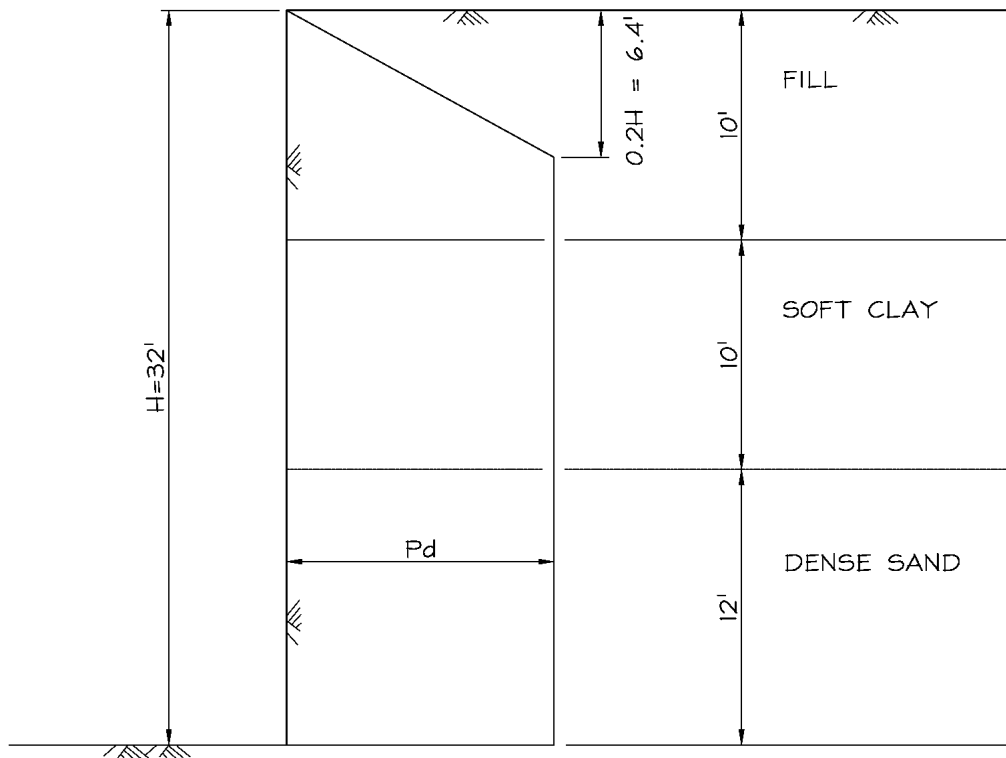

SOLUTION:

COMPUTE TOTAL ACTIVE PRESSURE RESULTANT (A_1) -

$$A_1 = (372)(10)/2 + (400 + 1400)(10)/2 + (594 + 1015)(12)/2 = \underline{20,514 \text{ lbs/ft}}$$

COMPUTE P_d -

$$P_d = \frac{1.4A_1}{0.9H} = \frac{1.4(20,514)}{0.9(32)} = \underline{997 \text{ psf}}$$



EXAMPLE 4.3 – DETERMINE PASSIVE RESISTANCE (COHESIONLESS SOIL)

PROBLEM:

DETERMINE THE PASSIVE RESISTANCE ACTING ON THE BOTTOM OF A STEEL SHEET PILE WALL EMBEDDED IN MEDIUM DENSE CLEAN SAND WITH THE FOLLOWING PROPERTIES.

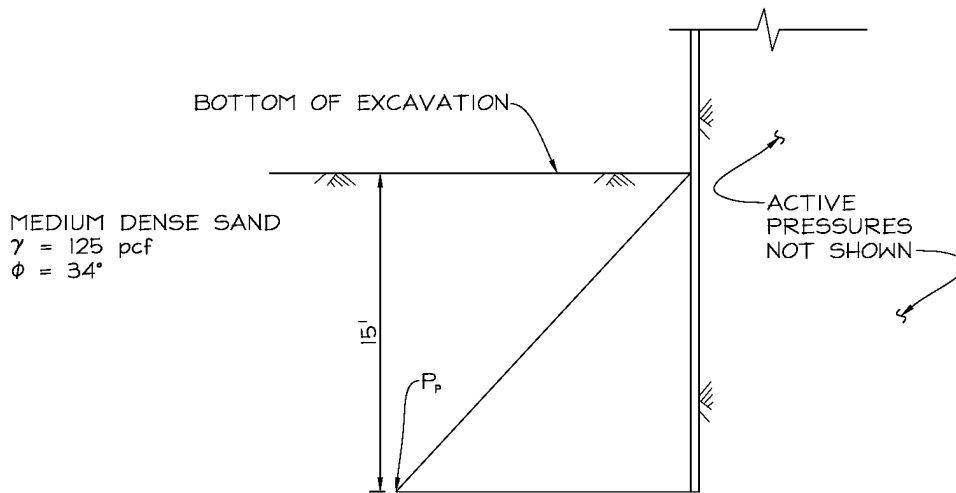

SOLUTION:

DETERMINE δ_{DESIGN} -

$\delta_{TYP} = 17^\circ$ FOR STEEL SHEET PILES AGAINST CLEAN SAND

$\delta_{TYP}/2 = 8.5^\circ (\leq 0.25\phi = 8.5^\circ)$

USE $\delta_{DESIGN} = 8.5^\circ$

USE LOG-SPIRAL THEORY TO COMPUTE K_p (REFER TO FIGURE 8, PAGE 4-10 OF THE CALTRANS TRENCHING AND SHORING MANUAL) -

$K_{p,\delta/\phi=1.0} = 9.5$ (FOR $\phi=34^\circ$ & $\beta/\phi=0$)

$\delta/\phi = -8.5/34 = -0.25$

REDUCTION FACTOR (R) ≈ 0.52

$K_p = RK_{p,\delta/\phi=1.0} = 0.52(9.5) = \underline{4.9}$

COMPUTE P_p -

$P_p = K_p(\gamma)(15') = 4.9(125)(15) = \underline{9188}$ psf



EXAMPLE 4.4 – DETERMINE PASSIVE RESISTANCE (COHESIVE SOIL)

PROBLEM:

DETERMINE THE PASSIVE RESISTANCE ACTING ON THE BOTTOM OF A SHORING WALL EMBEDDED IN MEDIUM CLAY WITH THE FOLLOWING PROPERTIES.

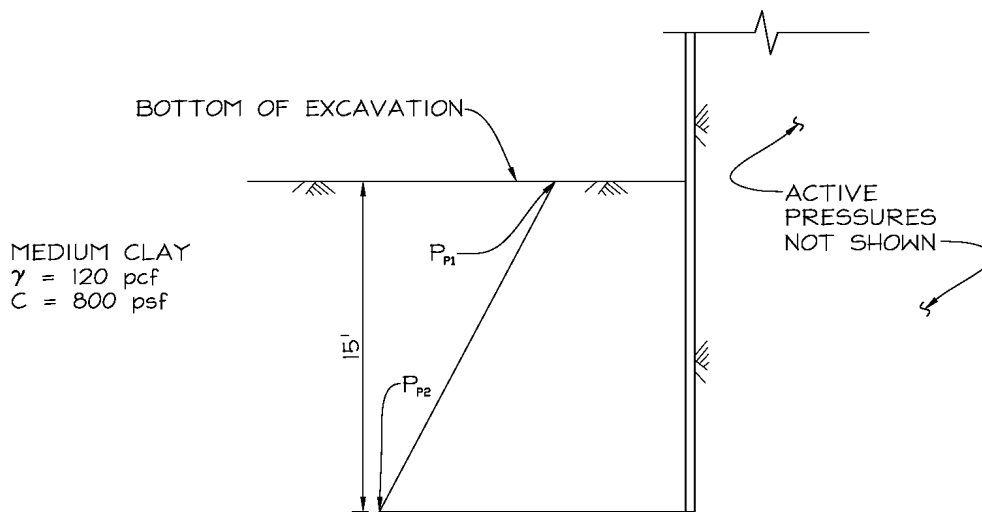

SOLUTION:

COMPUTE P_{p1} & P_{p2} -

$$P_{p1} = 2C = 2(800) = \underline{1600 \text{ psf}}$$

$$P_{p2} = P_{p1} + \gamma(15') = 1600 + 120(15) = \underline{3400 \text{ psf}}$$



EXAMPLE 5.1 – RAILROAD LIVE LOAD SURCHARGE FROM TWO TRACKS

PROBLEM:

COMPUTE THE LATERAL SURCHARGE PRESSURES ACTING ON THE SHORING WALL BASED ON THE FOLLOWING TRACK GEOMETRY.

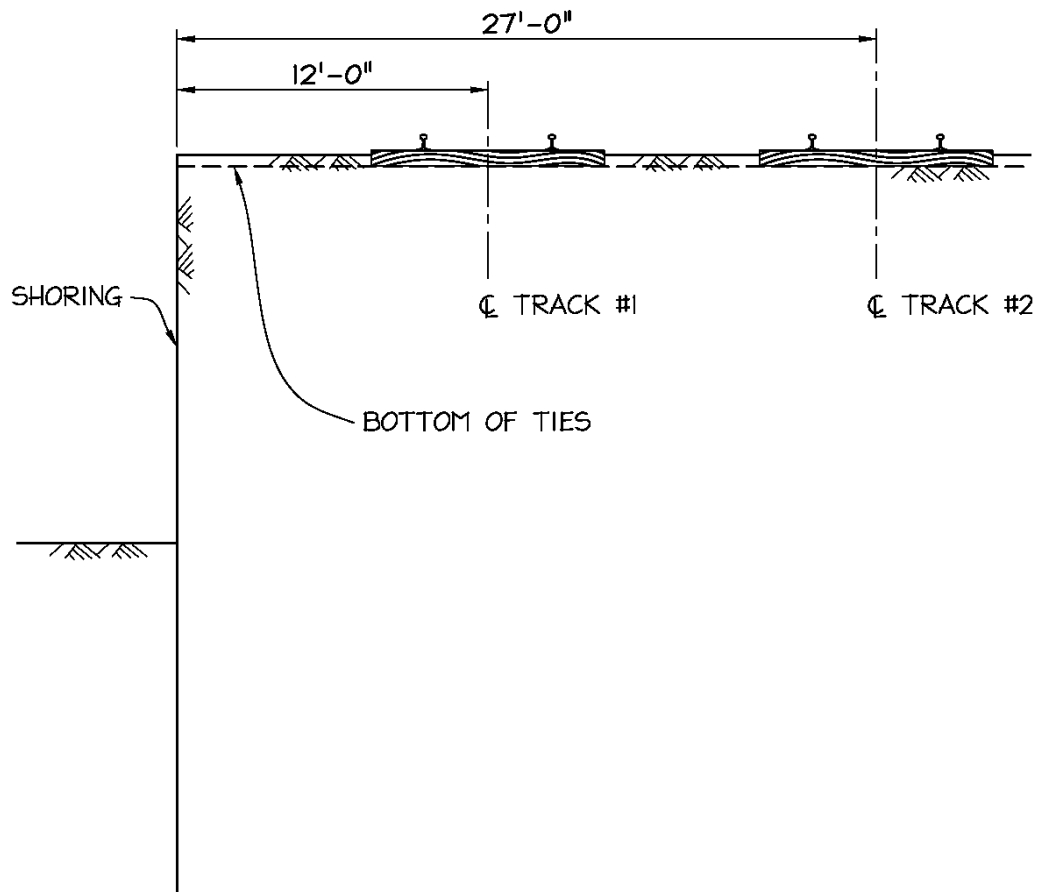



SOLUTION:

Centerline of Track #1 is 12 feet from face of shoring
 Centerline of Track #2 is 27 feet from face of shoring

d (feet)	P _{s,1} (psf)	P _{s,2} (psf)	P _{s,total} (psf)
1	161	29	190
2	305	57	362
3	418	84	502
4	496	110	606
5	541	134	674
6	558	156	713
7	553	175	729
8	535	192	727
9	507	207	714
10	474	219	693
11	439	229	668
12	404	236	640
13	370	241	611
14	338	244	582
15	307	246	553
16	280	245	525
17	254	244	498
18	231	241	472
19	210	237	447
20	191	232	423
21	174	227	401
22	159	221	379
23	145	214	359
24	133	208	340
25	122	201	322
26	112	194	305
27	102	187	289
28	94	180	274
29	87	173	260
30	80	166	246
31	74	160	234
32	69	153	222
33	64	147	211
34	59	141	200
35	55	135	190
36	51	129	180
37	48	124	171
38	45	118	163
39	42	113	155
40	39	109	148
41	37	104	141
42	34	100	134
43	32	95	128
44	30	91	122
45	29	87	116
46	27	84	111
47	25	80	106
48	24	77	101
49	23	74	97
50	21	71	92

d = depth below bottom of tie
 P_{s,1} = lateral surcharge from Track #1
 P_{s,2} = lateral surcharge from Track #2
 P_{s,total} = combined lateral surcharge from Tracks #1 and #2 = P_{s,1} + P_{s,2}

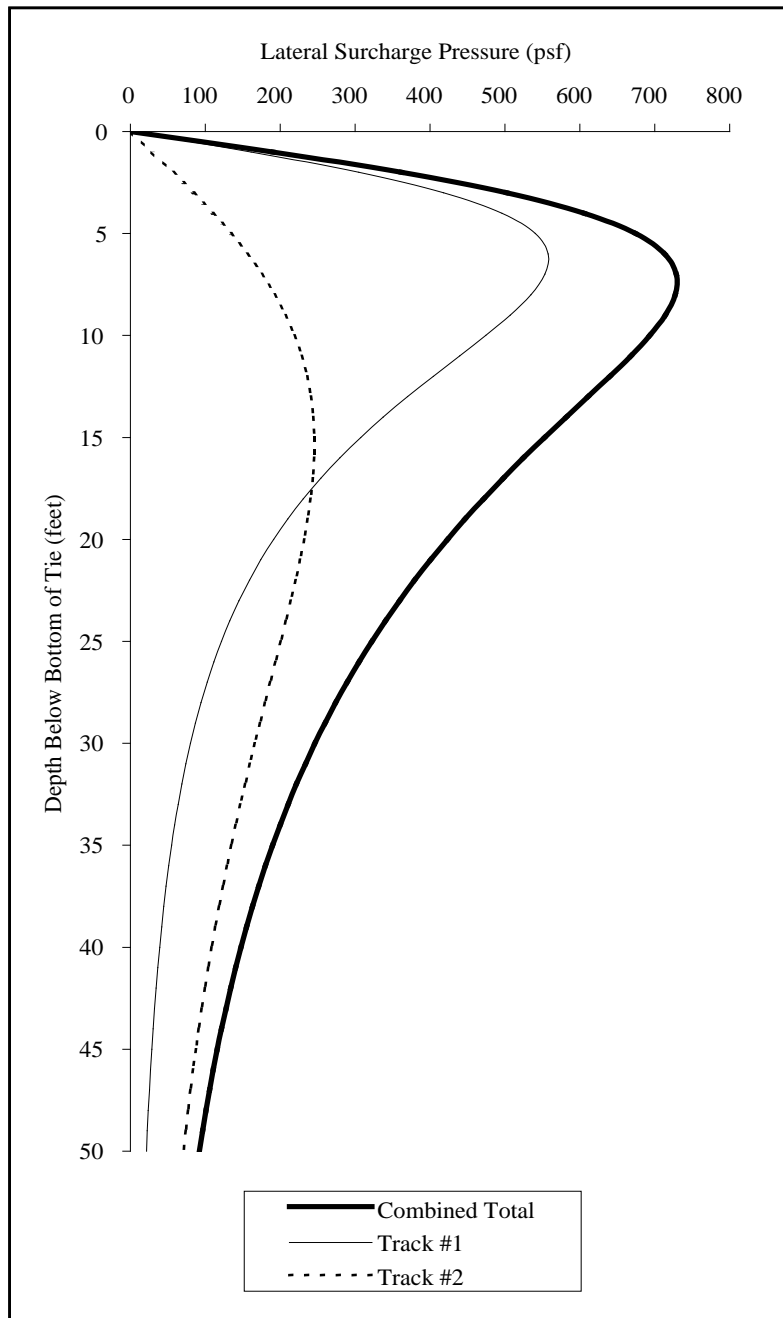



EXAMPLE 5.2 – RAILROAD LIVE LOAD SURCHARGE FROM THREE TRACKS

PROBLEM:

COMPUTE THE LATERAL SURCHARGE PRESSURES ACTING ON THE SHORING WALL BASED ON THE FOLLOWING TRACK GEOMETRY.

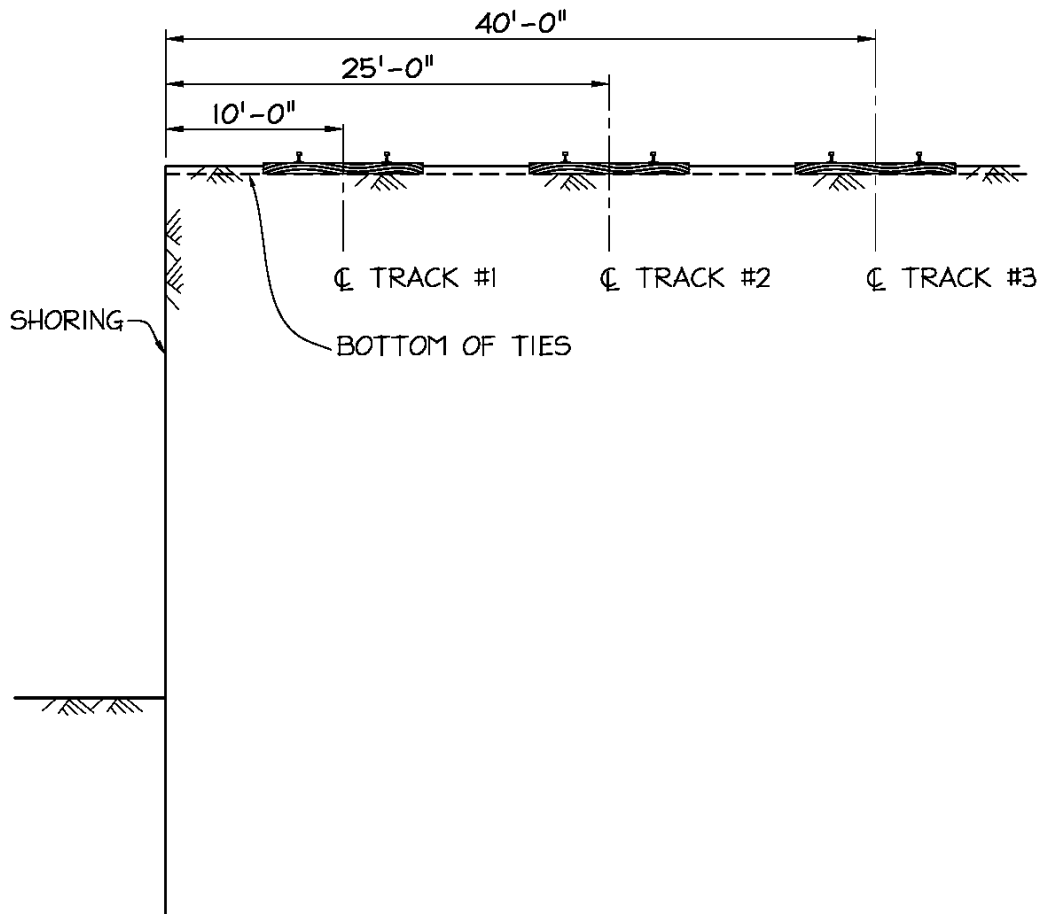



SOLUTION:

Centerline of Track #1 is 10 feet from face of shoring
 Centerline of Track #2 is 25 feet from face of shoring
 Centerline of Track #3 is 40 feet from face of shoring

d (feet)	P _{s,1} (psf)	P _{s,2} (psf)	P _{s,3} (psf)	0.5P _{s,3} (psf)	P _{s,total} (psf)
1	247	34	13	6	287
2	450	66	26	13	529
3	585	98	38	19	703
4	655	128	51	25	808
5	674	155	62	31	860
6	658	179	74	37	874
7	622	201	85	42	865
8	575	219	95	48	842
9	525	234	105	52	811
10	474	246	114	57	777
11	426	254	122	61	742
12	382	261	130	65	707
13	341	264	136	68	673
14	305	265	142	71	641
15	272	265	148	74	611
16	243	262	152	76	582
17	218	258	156	78	554
18	195	253	159	80	528
19	175	247	162	81	504
20	158	241	163	82	480
21	142	233	165	82	458
22	129	226	165	83	437
23	116	218	166	83	417
24	106	210	165	83	398
25	96	202	165	82	380
26	88	193	164	82	363
27	80	185	162	81	346
28	73	177	160	80	331
29	67	170	158	79	316
30	62	162	156	78	302
31	57	155	154	77	289
32	52	148	151	76	276
33	48	141	148	74	264
34	45	135	145	73	252
35	41	129	142	71	242
36	39	123	139	70	231
37	36	117	136	68	221
38	33	112	133	67	212
39	31	107	130	65	203
40	29	102	127	63	194
41	27	97	124	62	186
42	25	93	120	60	179
43	24	89	117	59	171
44	22	85	114	57	164
45	21	81	111	56	158
46	20	77	108	54	151
47	19	74	105	53	145
48	18	71	102	51	139
49	17	68	99	50	134
50	16	65	97	48	129

d = depth below bottom of tie
 P_{s,1} = lateral surcharge from Track #1
 P_{s,2} = lateral surcharge from Track #2
 P_{s,3} = lateral surcharge from Track #3
 P_{s,total} = combined lateral surcharge from Tracks #1, #2 & #3 = P_{s,1} + P_{s,2} + 0.5P_{s,3}

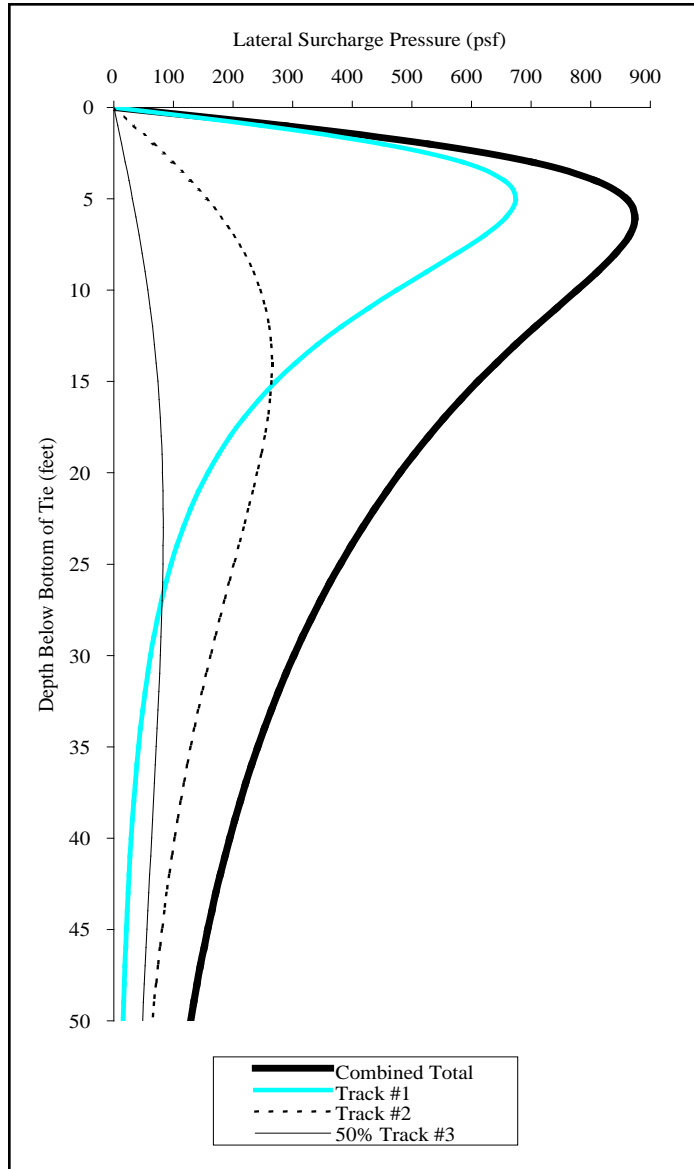



EXAMPLE 5.3 – “SIMPLIFIED” RAILROAD LIVE LOAD SURCHARGE

PROBLEM:

DEVELOP THE “SIMPLIFIED” LATERAL SURCHARGE PRESSURE DIAGRAM FOR A SINGLE TRACK WHOSE CENTERLINE IS LOCATED 15 FEET FROM THE FACE OF A SHORING WALL.

SOLUTION:

Centerline of track is 15 feet from face of shoring

d = depth below bottom of tie
P_s = Boussinesq lateral surcharge
P_{s,simple} = 0.8P_{s,max} = 0.8(444) = 355 psf

d (feet)	P _s (psf)
1	98
2	191
3	271
4	337
5	386
6	419
7	438
8	444
9	441
10	431
11	415
12	396
13	374
14	352
15	329
16	307
17	285
18	265
19	246
20	228
21	211
22	195
23	181
24	167
25	155
26	144
27	133
28	124
29	115
30	107
31	100
32	93
33	87
34	81
35	76
36	71
37	66
38	62
39	58
40	55
41	52
42	49
43	46
44	43
45	41
46	39
47	37
48	35
49	33
50	31

P_{s,max}

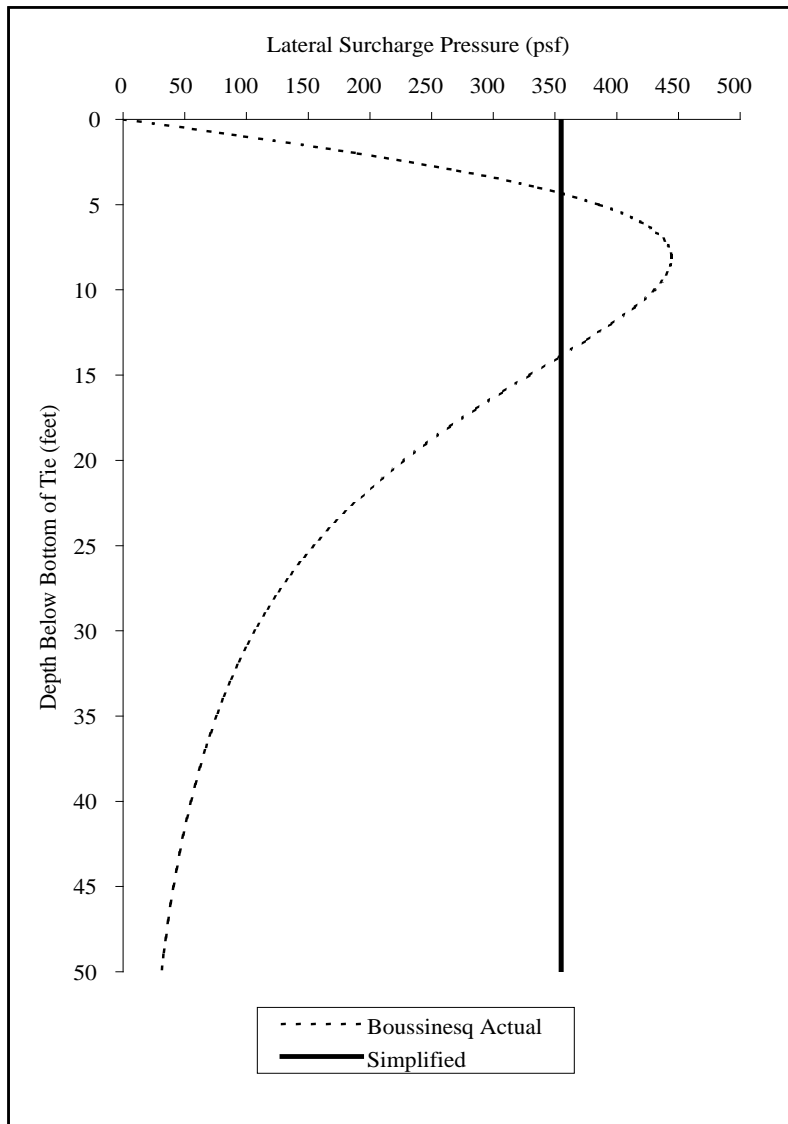



EXAMPLE 6.1 – CANTILEVER SOLDIER PILE AND LAGGING SHORING WALL

PROBLEM:

DETERMINE THE REQUIRED DEPTH OF PENETRATION AND THE DESIGN SHEAR AND MOMENT FOR A CANTILEVER SOLDIER PILE AND LAGGING WALL FOR THE SOIL CONDITIONS AND PILE SPACING INDICATED BELOW.

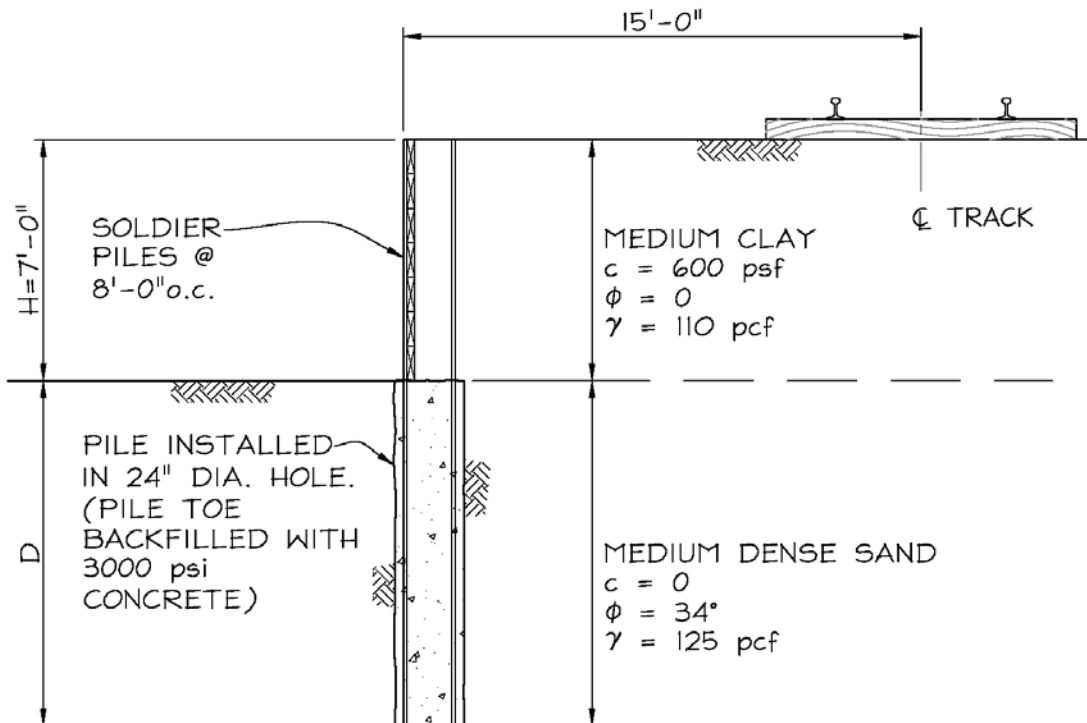



SOLUTION:

COMPUTE ACTIVE SOIL PRESSURES –

MEDIUM CLAY:

NO THEORETICAL NET ACTIVE PRESSURE BECAUSE

$$\gamma_{\text{CLAY}}H - 2c = 110(7) - 2(600) = -430 \text{ psf} < 0.$$

THEREFORE, USE 30 psf/ft EFP MINIMUM ACTIVE PRESSURE

MEDIUM DENSE SAND:

$$K_A = \tan^2(45^\circ - \phi/2) = \tan^2(45^\circ - 34^\circ/2) = \underline{0.28}$$

$$\text{ACTIVE GRADIENT} = K_A \gamma_{\text{SAND}} = 0.28(125) = \underline{35 \text{ psf/ft}}$$

COMPUTE PASSIVE SOIL PRESSURE USING LOG-SPIRAL THEORY –

REFER TO EXAMPLE 4.3: $K_P = \underline{4.9}$

$$\text{PASSIVE GRADIENT} = K_P \gamma_{\text{SAND}} = 4.9(125) = \underline{613 \text{ psf/ft}}$$

RAILROAD SURCHARGE –

USE “SIMPLIFIED” RAILROAD SURCHARGE (I.E., 80% OF MAXIMUM)

REFER TO EXAMPLE 5.3: $P_S = \underline{355 \text{ psf}}$

EFFECTIVE WIDTH OF EMBEDDED PORTION OF SOLDIER PILE –

PER TABLE 10-1 IN THE CALTRANS TRENCHING AND SHORING MANUAL

$$\text{EFFECTIVE WIDTH } (w_{\text{EFF}}) = (0.08\phi)d,$$

WHERE d = DIAMETER OF CONCRETE FILLED DRILLED HOLE

$$w_{\text{EFF}} = 0.08(34)(2) = 5.4 \text{ feet}$$

USE “SIMPLIFIED” METHOD OF CANTILEVER PILE ANALYSIS



SHORING LOADING DIAGRAM -

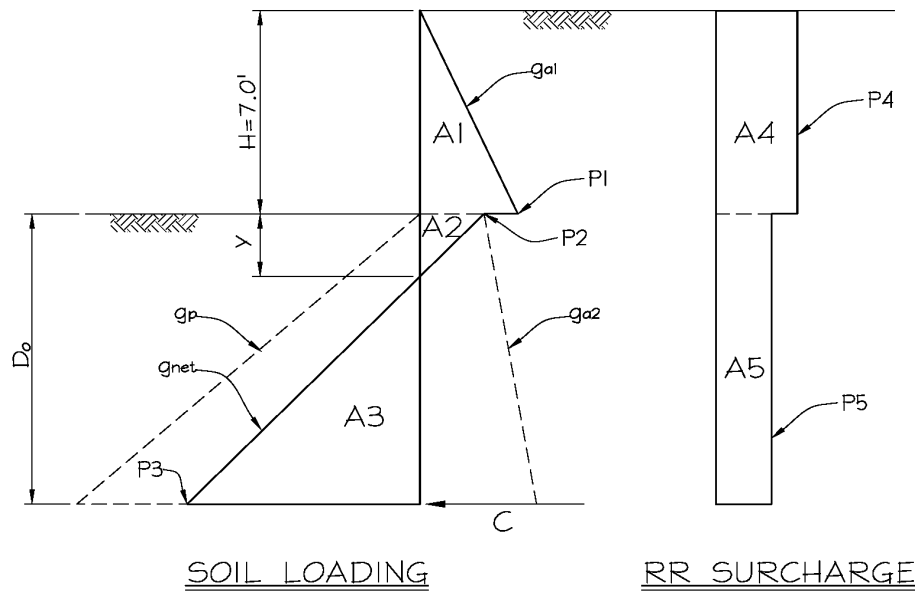

$$g_{a1} = 30(\text{PILE SPACING}) = 30(8) = \underline{240 \text{ psf}}$$

$$g_{a2} = 35W_{\text{EFF}} = 35(5.4) = \underline{189 \text{ psf}}$$

$$g_p = 613W_{\text{EFF}} = 613(5.4) = \underline{3310 \text{ psf}}$$

$$g_{\text{net}} = g_p - g_{a2} = 3310 - 189 = \underline{3121 \text{ psf}}$$

$$P_1 = 240H = 240(7) = \underline{1680 \text{ lbs/ft}}$$

$$P_2 = K_A \gamma_{\text{clay}} H W_{\text{EFF}} = 0.28(110)(7)(5.4) = \underline{1164 \text{ lbs/ft}}$$

$$P_3 = g_{\text{net}} D_o - P_2 = \underline{3121 D_o - 1164 \text{ lbs/ft}}$$

$$P_4 = 355(\text{PILE SPACING}) = 355(8) = \underline{2840 \text{ lbs/ft}}$$

$$P_5 = 355W_{\text{EFF}} = 355(5.4) = \underline{1917 \text{ lbs/ft}}$$

$$Y = P_2 / g_{\text{net}} = 1164 / 3121 = \underline{0.37 \text{ feet}}$$

$$A1 = P_1(H/2) = 1680(7/2) = \underline{5880 \text{ lbs}}$$

$$A2 = P_2(Y/2) = 1164(0.37/2) = \underline{215.3 \text{ lbs}}$$

$$A3 = P_3(D_o - Y)/2 = (3121 D_o - 1164)(D_o - 0.37)/2$$

$$= \underline{1560.5 D_o^2 - 1159.4 D_o + 215.3 \text{ lbs}}$$

$$A4 = P_4 H = 2840(7) = \underline{19,880 \text{ lbs}}$$

$$A5 = P_5 D_o = \underline{1917 D_o \text{ lbs}}$$



COMPUTE REQUIRED EMBEDMENT DEPTH -

SUM MOMENTS ABOUT BOTTOM OF WALL TO DETERMINE D_o -

$$A_1(D_o+H/3) + A_2(D_o-Y/3) - A_3(D_o-Y)/3 + A_4(D_o+H/2) + A_5(D_o/2) = 0$$

$$5880(D_o+7/3) + 215.3(D_o-0.37/3) - (1560.5D_o^2-1159.4D_o+215.3)(D_o-0.37)/3 + 19,880(D_o+7/2) + 1917D_o(D_o/2) = 0$$

$$520.2D_o^3 - 1537.3D_o^2 - 25,761D_o - 83,300 = 0$$

SOLVE FOR D_o :

$$D_o = \underline{9.74 \text{ feet}}$$

INCREASE EMBEDMENT DEPTH BY 20% TO ACCOUNT FOR "SIMPLIFIED" ANALYSIS AND THEN ADD AN ADDITIONAL 40% FOR SAFETY FACTOR.

$$D = 1.4(1.2(9.74)) = \underline{16.4 \text{ feet}} \text{ MINIMUM}$$

PROVIDE 17 feet OF EMBEDMENT

DETERMINE DESIGN SHEAR FORCE -

MAXIMUM SHEAR FORCE IS AT BOTTOM OF PILE

$$V_{MAX} = A_3 - A_1 - A_2 - A_4 - A_5$$

$$= (1560.5D_o^2 - 1159.4D_o + 215.3) - 5880 - 215.3 - 19,880 - 1917D_o$$

$$= [1560.5(9.74)^2 - 1159.4(9.74) + 215.3 - 5880 - 215.3 - 19,880 - 1917(9.74)]/1000$$

$$V_{MAX} = \underline{92 \text{ kips}}$$

DETERMINE DESIGN MOMENT -

FIND POINT OF ZERO SHEAR (depth of X below bottom of excavation)

$$A_1 + A_2 + A_4 + P_5X - P_3(X-Y)/2 = 0$$

$$5880 + 215.3 + 19,880 + 1917X - (3121X - 1164)(X - 0.37)/2 = 0$$

$$1560.5X^2 - 3076.4X - 25832 = 0$$

SOLVE FOR X:

$$X = \underline{5.17 \text{ feet}}$$

$$M_{MAX} = A_1(X+H/3) + A_2(X-Y/3) + A_4(Y+H/2) + P_5X^2/2 - P_3(X-Y)^2/6$$

$$= [5880(5.17+7/3) + 215.3(5.17-0.37/3) + 19,880(5.17+7/2) + 1917(5.17)^2/2 - (3121(5.17)-1164)(5.17-0.37)^2/6]/1000$$

$$M_{MAX} = \underline{186 \text{ kip-ft}}$$



EXAMPLE 6.2 – SHEET PILE SHORING WALL WITH ONE LEVEL OF BRACING (FREE EARTH SUPPORT METHOD)

PROBLEM:

DETERMINE THE REQUIRED DEPTH OF PENETRATION, THE DESIGN SHEAR AND MOMENT, AND THE BRACING REACTION FOR A SHEET PILE SHORING WALL WITH A SINGLE LEVEL OF BRACING IN THE SOIL CONDITIONS INDICATED. USE THE FREE EARTH SUPPORT METHOD OF ANALYSIS.

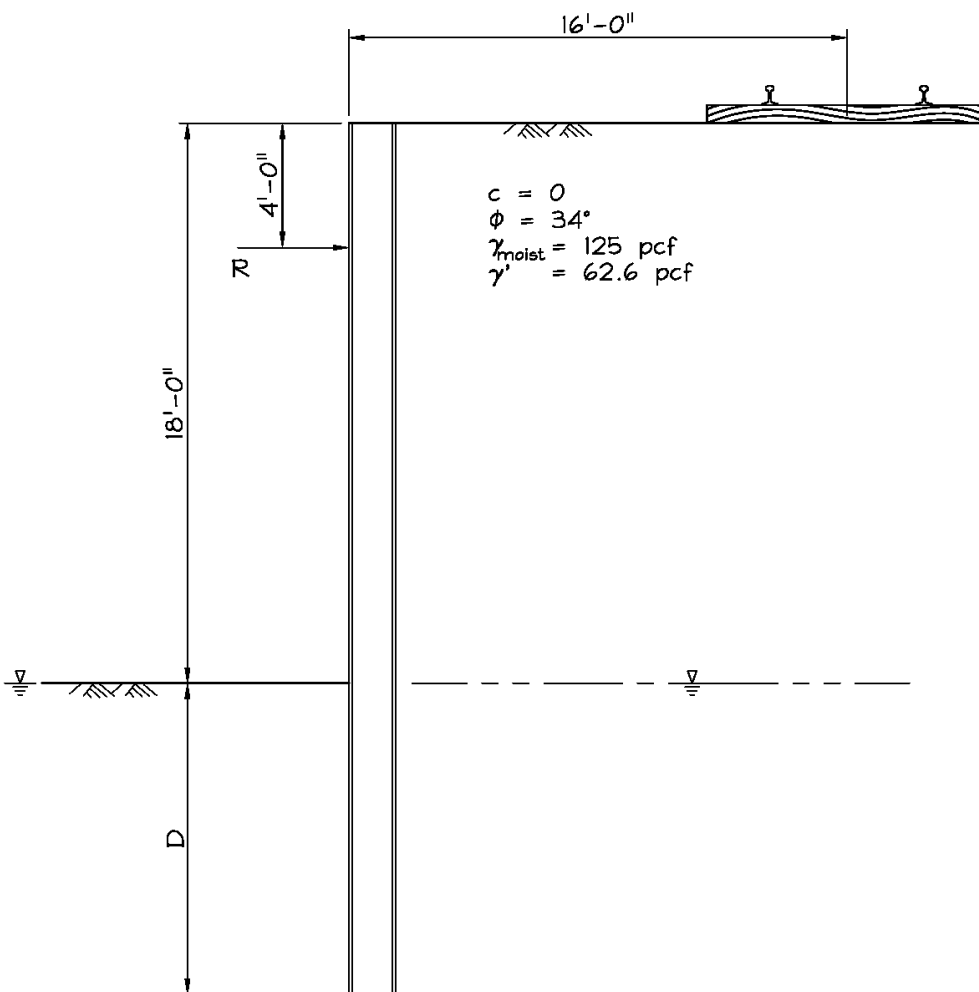

SOLUTION:



COMPUTE ACTIVE SOIL PRESSURES USING RANKINE THEORY -

$$K_A = \tan^2(45^\circ - \phi/2) = \tan^2(45^\circ - 34^\circ/2) = \underline{0.28}$$

$$\text{ACTIVE GRADIENT ABOVE GWT} = K_A \gamma_{\text{MOIST}} = 0.28(125) = \underline{35 \text{ psf/ft}}$$

$$\begin{aligned} \text{ACTIVE GRADIENT BELOW GWT (INCLUDING WATER PRESSURE)} &= K_A \gamma' + \gamma_w \\ &= 0.28(62.6) + 62.4 = \underline{80 \text{ psf/ft}} \end{aligned}$$

COMPUTE PASSIVE SOIL PRESSURE USING LOG-SPIRAL THEORY -

REFER TO EXAMPLE 4.3: $K_P = 4.9$

$$\begin{aligned} \text{PASSIVE GRADIENT BELOW GWT (INCLUDING WATER PRESSURE)} &= K_P \gamma' + \gamma_w \\ &= 4.9(62.6) + 62.4 = \underline{369 \text{ psf/ft}} \end{aligned}$$

SHORING LOADING DIAGRAM -

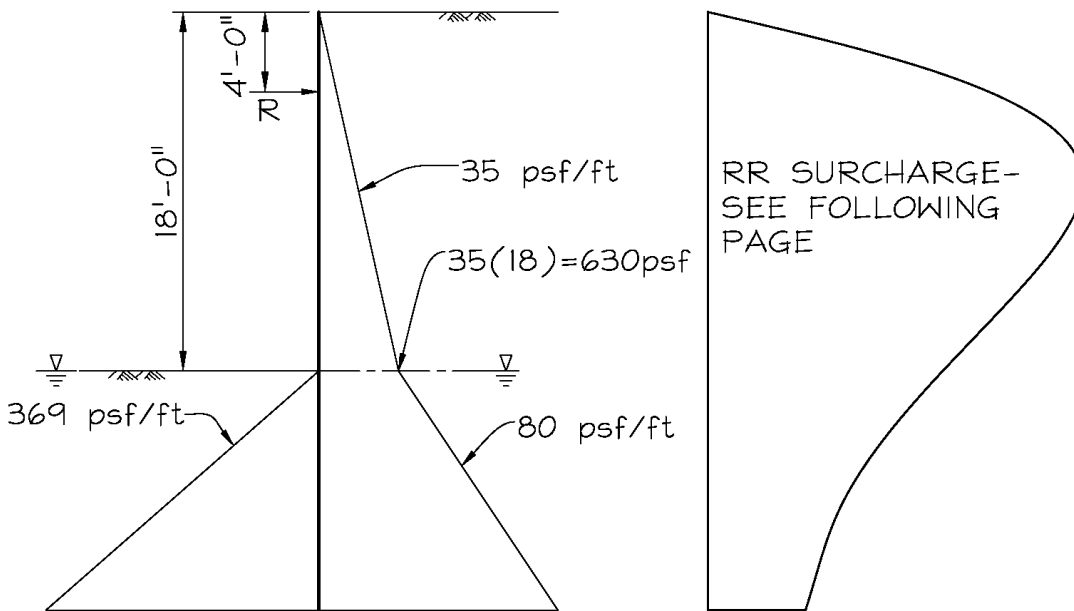



RAILROAD SURCHARGE PRESSURE DIAGRAM -

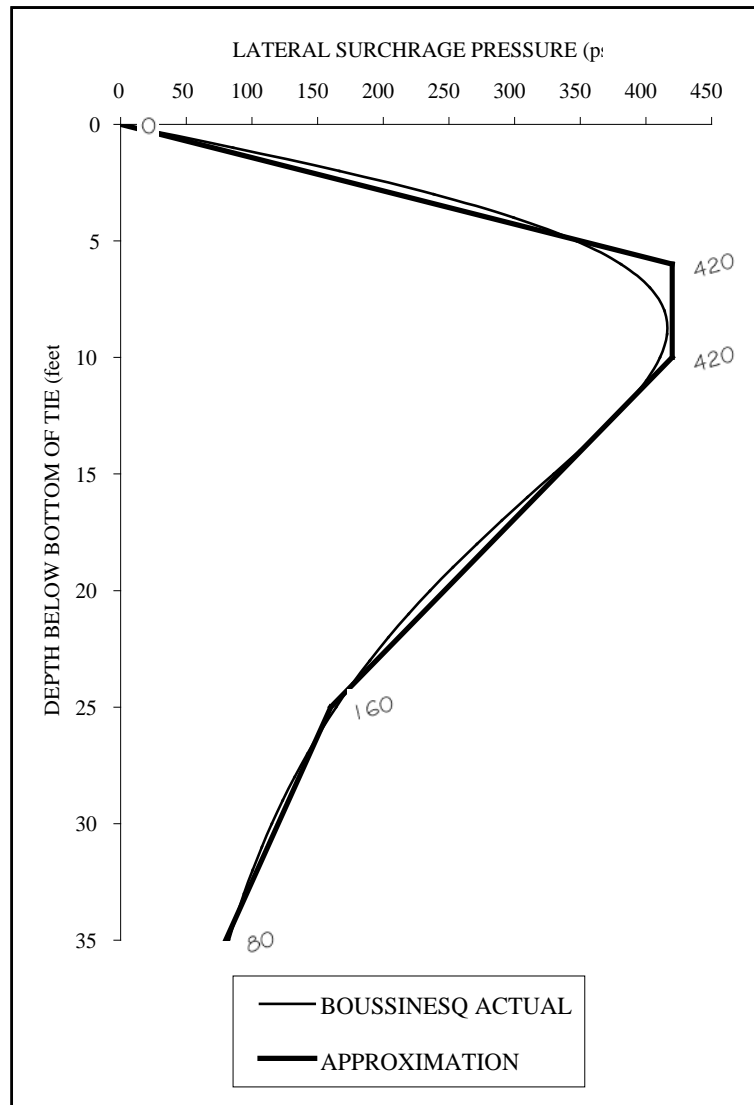

ANALYZE SHORING WALL USING BEAM ANALYSIS SOFTWARE TO DETERMINE DEPTH OF EMBEDMENT REQUIRED FOR STABILITY (I.E., SUM OF MOMENTS ABOUT BRACING LEVEL EQUAL TO ZERO).

THE COMPUTED BRACING REACTION, REQUIRED DEPTH OF EMBEDMENT, SHEAR AND MOMENT DIAGRAMS, AND ELASTIC WALL DEFLECTIONS ARE SHOWN ON THE FOLLOWING PAGE.

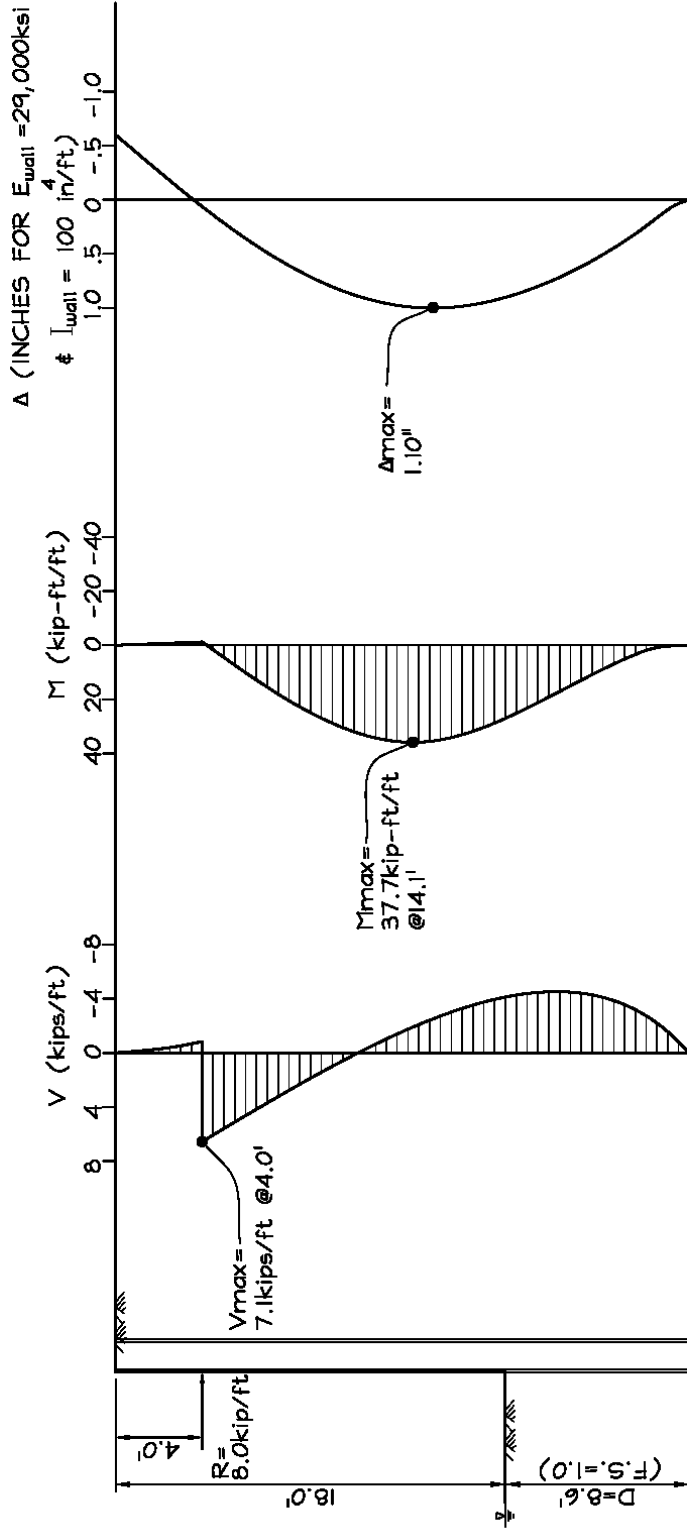

$D = 1.4(8.6) = 12.0'$
 USE 12' TOE EMBEDMENT



EXAMPLE 6.3 – SHEET PILE SHORING WALL WITH ONE LEVEL OF BRACING (FIXED EARTH SUPPORT METHOD)

PROBLEM:

REANALYZE THE SHORING WALL DESCRIBED IN EXAMPLE 6.2 USING THE FIXED EARTH SUPPORT METHOD OF ANALYSIS TO DETERMINE THE REQUIRED DEPTH OF PENETRATION, THE DESIGN SHEAR AND MOMENT, AND THE BRACING REACTION.

SOLUTION:

SOIL AND SURCHARGE PRESSURES ARE THE SAME AS THOSE USED IN EXAMPLE 6.2.

ANALYZE SHORING WALL USING BEAM ANALYSIS SOFTWARE TO DETERMINE DEPTH OF EMBEDMENT REQUIRED TO PROVIDE EFFECTIVE FIXITY.

THE COMPUTED BRACING REACTION, REQUIRED DEPTH OF EMBEDMENT, SHEAR AND MOMENT DIAGRAMS, AND ELASTIC WALL DEFLECTIONS ARE SHOWN ON THE FOLLOWING PAGE.

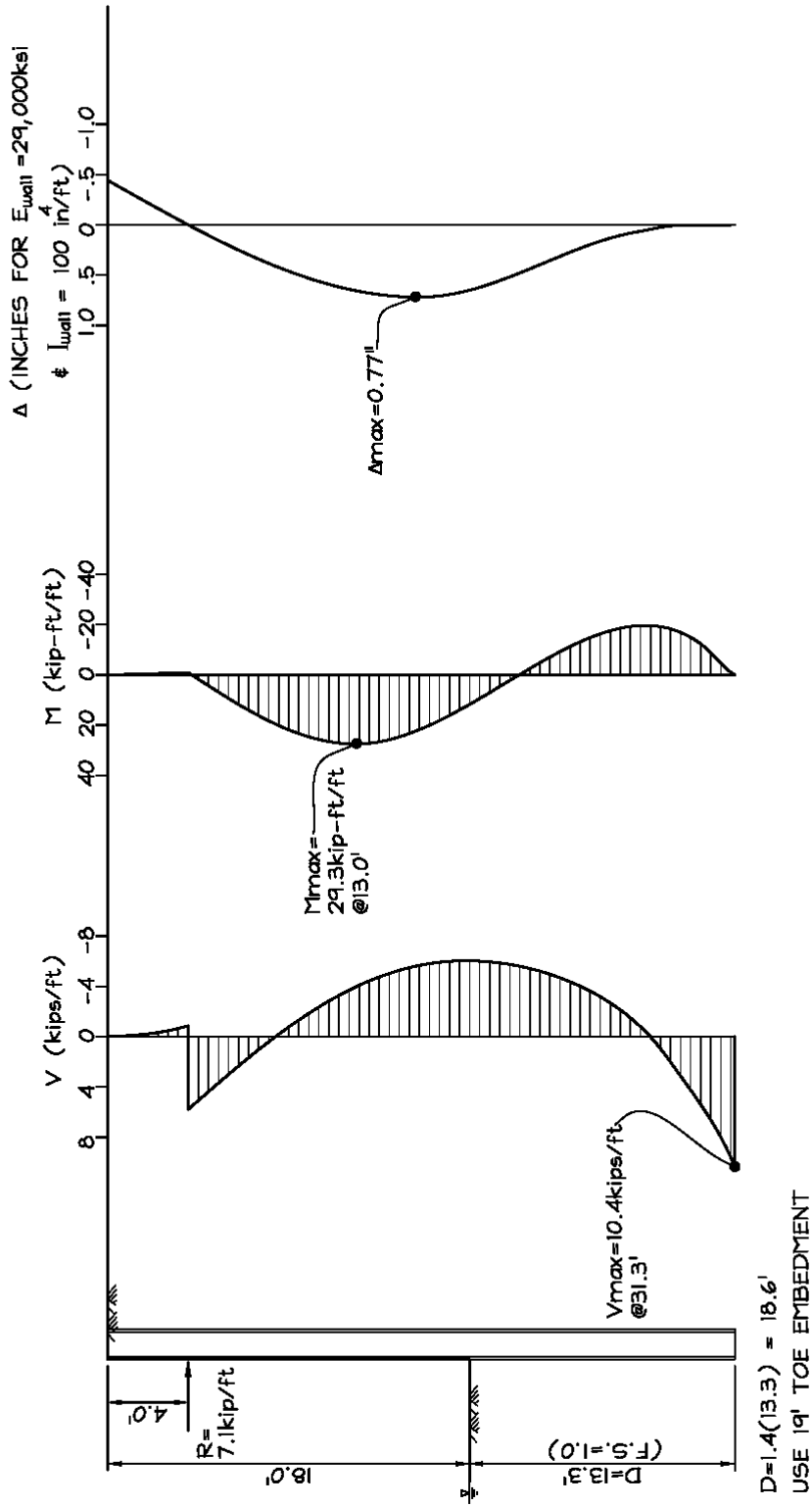



COMPARISON OF RESULTS FROM FREE EARTH AND FIXED EARTH SUPPORT METHODS –

ITEM	FREE EARTH (EXAMPLE 6.2)	FIXED EARTH (EXAMPLE 6.3)
DEPTH OF EMBEDMENT	12 feet	19 feet
BRACING REACTION	8.0 kips/ft	7.1 kips/ft
M_{MAX}	37.7 kip-ft/ft	29.3 kip-ft/ft
V_{MAX}	7.1 kips/ft	10.6 kips/ft
MAX. ELASTIC WALL DEFLECTION*	1.10 inches	0.77 inches

*FOR $I_{WALL}=100 \text{ in}^4/\text{ft}$ & $E_{WALL}=29,000 \text{ ksi}$



EXAMPLE 6.4 – ANALYSIS OF A DIAPHRAGM SHORING WALL WITH THREE LEVELS OF BRACING

PROBLEM:

DETERMINE THE REQUIRED DEPTH OF PENETRATION, THE DESIGN SHEAR AND MOMENT, AND THE BRACING REACTIONS FOR A SOIL-MIX SHORING WALL SUPPORTED WITH THREE LEVELS OF BRACING IN THE SOIL CONDITIONS INDICATED. ASSUME THE WIDE FLANGE PILE INSERTS ARE SPACED AT 4 FEET ON-CENTER. ANALYZE FULL DEPTH CONDITION ONLY.

SOIL-MIX WALL (UNREINFORCED) IS EXTENDED TO STIFF CLAY LAYER FOR GROUNDWATER CUT-OFF.

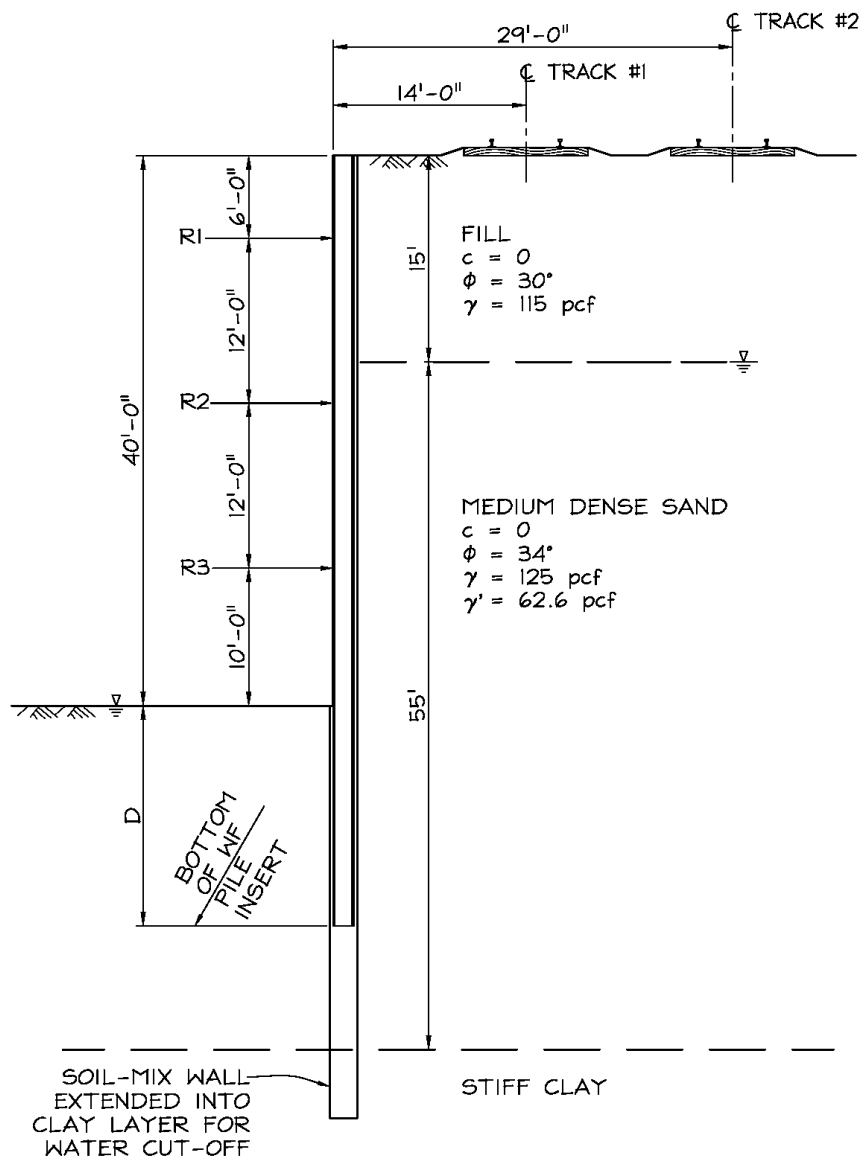



SOLUTION:

DEVELOP APPARENT SOIL PRESSURE DIAGRAM –

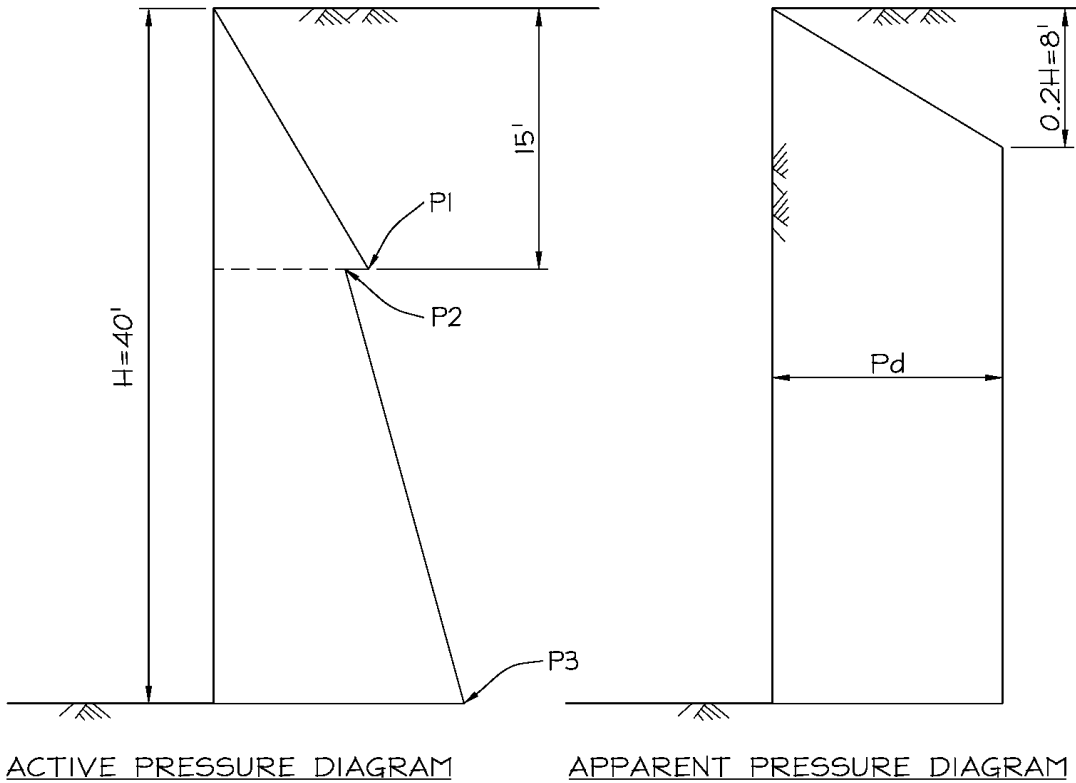

ACTIVE SOIL PRESSURES –

$$K_{A,FILL} = \tan^2(45^\circ - \phi_{FILL}/2) = \tan^2(45^\circ - 30^\circ/2) = \underline{0.33}$$

$$K_{A,DENSE\ SAND} = \tan^2(45^\circ - \phi_{DENSE\ SAND}/2) = \tan^2(45^\circ - 34^\circ/2) = \underline{0.28}$$

$$P1 = K_{A,FILL}(\gamma_{FILL})(15') = 0.33(115)(15) = \underline{569\ psf}$$

$$P2 = K_{A,DENSE\ SAND}(\gamma_{FILL})(15') = 0.28(115)(15) = \underline{483\ psf}$$

$$P3 = P2 + K_{A,DENSE\ SAND}(\gamma')(25') = 483 + 0.28(62.6)(25) = \underline{921\ psf}$$

CALCULATE APPARENT PRESSURE –

$$\text{ACTIVE SOIL PRESSURE RESULTANT } (A_r) = P1(15'/2) + [(P2+P3)/2](25')$$

$$= 569(15/2) + [(483+921)/2](25) = \underline{21,818\ lbs/ft}$$

$$P_d = 1.4(A_r)/(0.9H) = 1.4(21,818)/[0.9(40)] = \underline{848\ psf}$$



SHORING LOADING DIAGRAM –

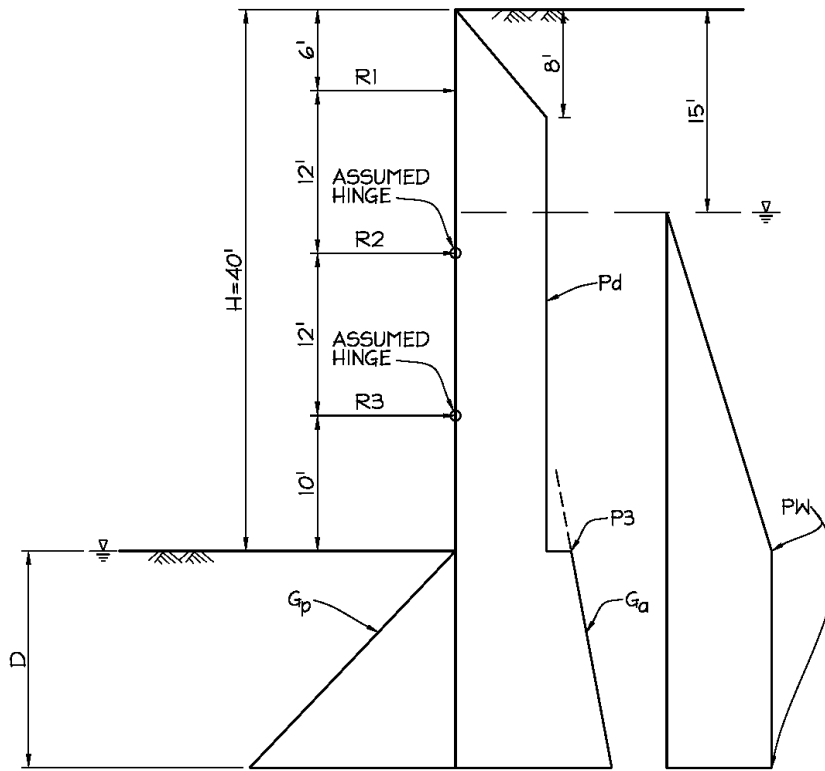

DESIGN SOIL & WATER PRESSURES*

* FOR RR SURCHARGE SEE NEXT PAGE

APPARENT SOIL PRESSURE

$$P_d = 848 \text{ psf (SEE PREVIOUS PAGE)}$$

ACTIVE SOIL PRESSURES IN DENSE SAND BELOW EXCAVATION SUBGRADE

$$P_3 = 921 \text{ psf (SEE PREVIOUS PAGE)}$$

ACTIVE SOIL GRADIENT BELOW EXCAVATION SUBGRADE (G_a)

$$= K_{A,DENSE\ SAND}(\gamma') = 0.28(62.6) = 17.5 \text{ psf/ft}$$

PASSIVE SOIL PRESSURES IN DENSE SAND BELOW EXCAVATION SUBGRADE

$$K_p = 4.9 \text{ (REFER TO EXAMPLE 4.3)}$$

PASSIVE SOIL GRADIENT BELOW EXCAVATION SUBGRADE (G_p)

$$= K_p(\gamma') = 4.9(62.6) = 307 \text{ psf/ft}$$

NET HYDROSTATIC PRESSURE

$$PW = \gamma_w(25') = 62.4(25) = 1560 \text{ psf}$$



RAILROAD SURCHARGE PRESSURE DIAGRAM –

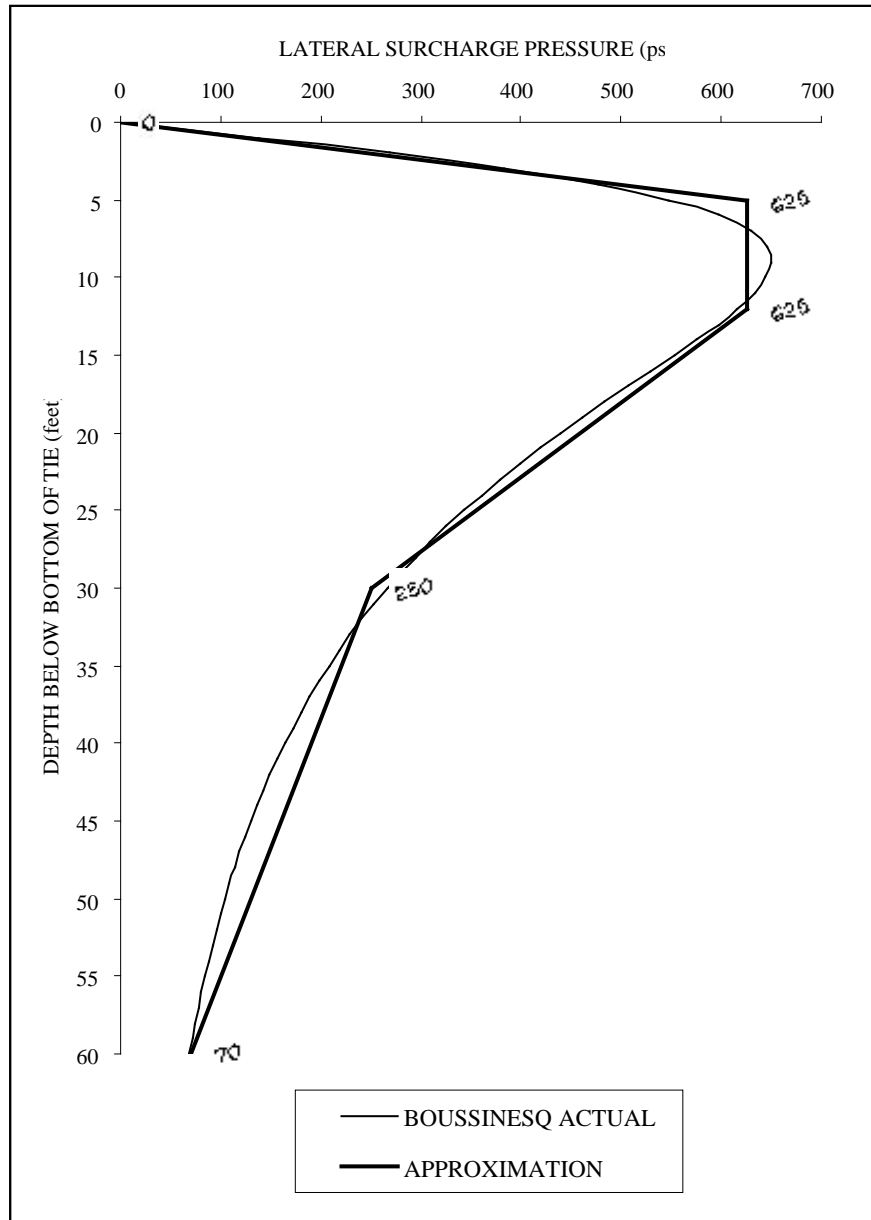

ANALYZE SHORING WALL USING BEAM ANALYSIS SOFTWARE TO DETERMINE DEPTH OF EMBEDMENT REQUIRED FOR STABILITY (I.E., BALANCE MOMENTS DUE TO LOADS ACTING BELOW THE LOWEST BRACING LEVEL).

THE COMPUTED BRACING REACTIONS, REQUIRED DEPTH OF EMBEDMENT, AND SHEAR AND MOMENT DIAGRAMS ARE SHOWN ON THE FOLLOWING PAGE.

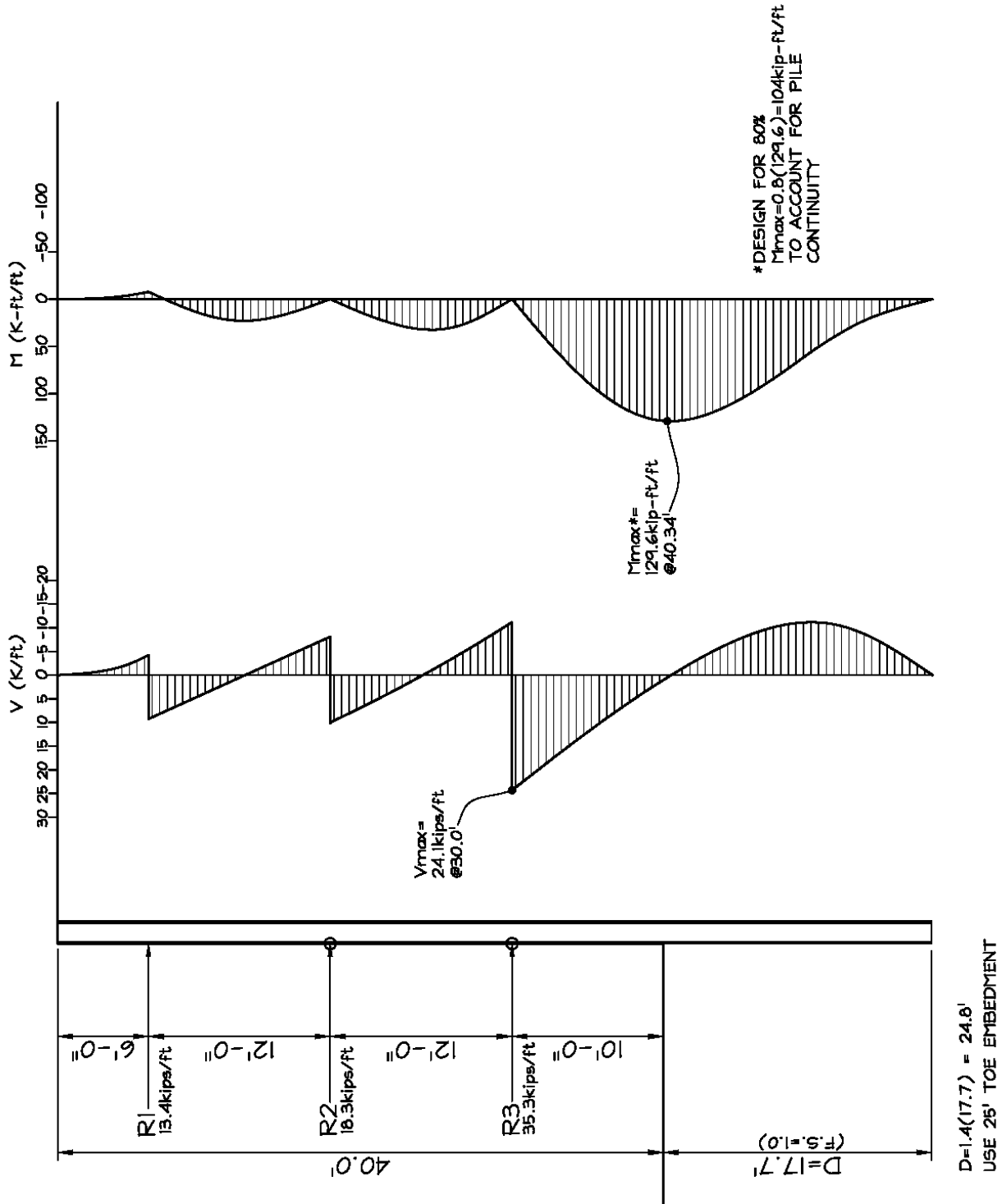



SUMMARY OF RESULTS

BRACING REACTIONS

$$R_1 = \underline{13.4 \text{ kips/ft}}$$

$$R_2 = \underline{18.3 \text{ kips/ft}}$$

$$R_3 = \underline{35.3 \text{ kips/ft}}$$

REQUIRED EMBEDMENT DEPTH = 25 feet

DESIGN (MAXIMUM) SHEAR

$$V_{\text{MAX}} = \underline{24.1 \text{ kips/ft}}$$

$$V_{\text{MAX}} = 24.1(4) = \underline{96.4 \text{ kips/pile}}$$

DESIGN (MAXIMUM) MOMENT

$$M_{\text{MAX}} = \underline{104 \text{ kip-ft/ft}}$$

$$M_{\text{MAX}} = 104(4) = \underline{416 \text{ kip-ft/pile}}$$



EXAMPLE 7.1 – WIDE FLANGE WALE DESIGN

PROBLEM:

SIZE A WALE FOR THE FOLLOWING BRACING GEOMETRY AND LOADING.

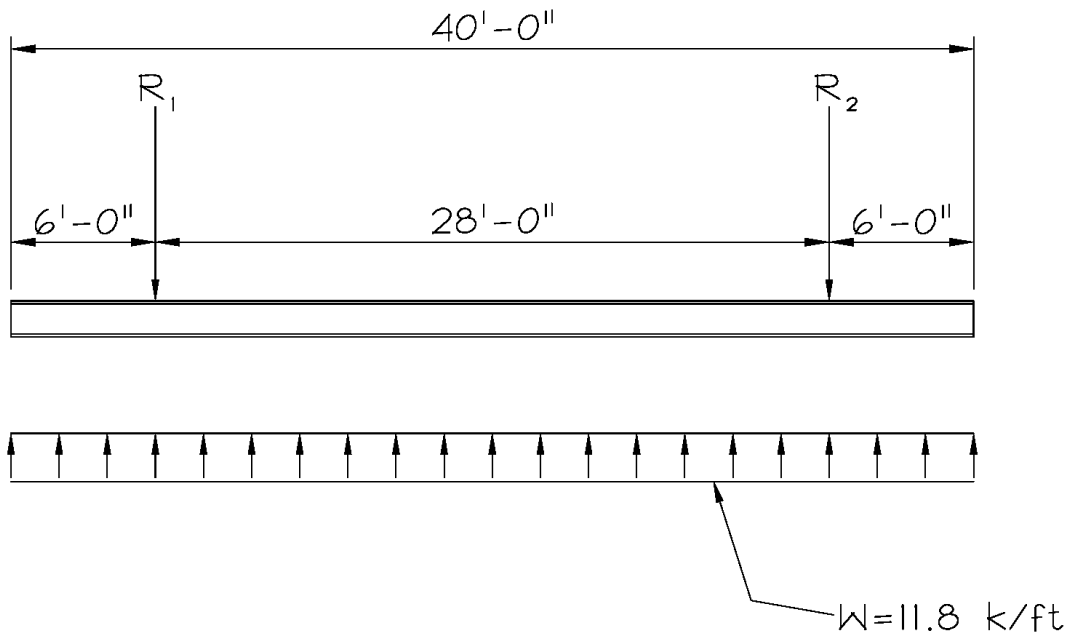



SOLUTION:

ANALYZE WALER TO DETERMINE DESIGN MOMENT AND SHEAR -

$$M_{MAX} = \frac{11.8(28)^2}{8} - \frac{11.8(6)^2}{2} = \underline{944 \text{ kip-ft}}$$

$$V_{MAX} = \frac{11.8(28)}{2} = \underline{165.2 \text{ kips}}$$

$$\text{STRUT LOADS} = R_1 = R_2 = \frac{11.8(40)}{2} = \underline{236 \text{ kips}}$$

ASSUMPTIONS -

USE GRADE 36 WIDE FLANGE BEAM FOR WALER

PROVIDE BRACING FOR WALER AT SPACING NO GREATER THAN $L_b \leq L_p$

$$\rightarrow M_n = M_p = (F_Y)(Z) \text{ (EQ. F2-1) AND } M_{all} = M_n/\Omega_b$$

$$\rightarrow V_n = 0.6(F_Y)(A_w)(C_v) \text{ (EQ. G2-1), } C_v = 1.0 \text{ (EQ. G2-2) AND } V_{all} = V_n/\Omega_v$$

PROVIDE SUFFICIENT SUPPORT FOR WALER SO WEAK AXIS BENDING IS NEGLIGIBLE

COMPUTE REQUIRED SECTION PROPERTIES -

$$Z_{REQD} = \Omega_b(M_{MAX})(12) / F_Y = 1.67(944)(12) / (36) = \underline{526 \text{ in}^3}$$

$$A_{WEB,REQD} = \Omega_v(V_{MAX}) / \{0.6(F_Y)\} = 1.50(165.2) / \{0.6(36)\} = \underline{11.5 \text{ in}^2}$$

ACCEPTABLE SIZES*	Z (in ³)	A _{WEB} (in ²)
W24X192	559	20.6
W27X178	570	20.2
W30X173	607	19.9

OTHER ACCEPTABLE SIZES ARE AVAILABLE

*NOTE: NEED FOR STIFFENERS HAS NOT BEEN CONSIDERED IN THIS DESIGN EXAMPLE.

**EXAMPLE 7.2 – PIPE STRUT DESIGN****PROBLEM:**

DESIGN A PIPE STRUT FOR THE STRUT LOAD (236 kips) COMPUTED IN EXAMPLE 7.1. ASSUME STRUT LENGTH (UNBRACED) IS 38 feet.

SOLUTION:

DETERMINE MINIMUM CROSS-SECTIONAL AREA REQUIRED BASED ON THE 12 ksi MAXIMUM AXIAL STRESS CRITERION –

$$A_{REQD} = \frac{\text{STRUT LOAD}}{12} = \frac{236}{12} = \underline{19.7 \text{ in}^2}$$

TRY 18" DIA. X 3/8" WALL THICKNESS PIPE, ASTM A252, GRADE 2 ($F_Y=35$ ksi) -

PIPE PROPERTIES

$$A = 19.4 \text{ in}^2$$

$$I = 754 \text{ in}^4$$

$$r = 6.24 \text{ in}$$

$$S = 83.8 \text{ in}^3$$

$$Z = 109 \text{ in}^3$$

$$D/t = 51.6 < 0.45(E) / (F_Y) = 372.9$$

$$\text{WEIGHT (W)} = 71 \text{ lbs/ft}$$

$$M_{\text{SELF WEIGHT}} = \frac{WL^2}{8} = \frac{71(38)^2}{8} = 12,816 \text{ LB-FT} = \underline{12.82 \text{ kip-ft}}$$

DETERMINE FLEXURAL CAPACITY –

$$M_n = M_p = (F_Y)(Z) \text{ (EQ. F8-1) AND } M_{\text{all}} = M_n / \Omega_b$$

$$M_{\text{all}} = (F_Y)(Z) / \{\Omega_b(12)\} = 35(109) / \{1.67(12)\} = \underline{190.4 \text{ kip-ft}}$$

DETERMINE AXIAL CAPACITY –

$$P_n = (F_{cr})(A_g) \text{ (EQ. E3-1) AND } P_{\text{all}} = P_n / \Omega_c$$

$$kL/r = 1.0(38)(12) / 6.24 = 73.08 < 120$$

$$F_{cr} = 0.658^{(F_Y)/(F_e)}(F_Y) \text{ (EQ. E3-2) FOR } F_e > 0.44(F_Y)$$

$$F_e = \pi^2 E / (kL/r)^2 \text{ (EQ. E3-4)}$$

$$F_e = \pi^2(29,000) / (73.08)^2 = 53.6 \text{ ksi} > 0.44(35) = 15.4 \text{ ksi}$$

$$F_{cr} = 0.658^{(35)/(53.6)}(35) = 26.6 \text{ ksi}$$

$$P_{\text{all}} = (F_{cr})(A_g) / \Omega_c = 26.6(19.4) / 1.67 = \underline{309 \text{ kips}}$$

CHECK COMBINED AXIAL LOAD AND BENDING –

$$(P_r)/(P_c) + (8/9)(M_r)/(M_c) \leq 1.0 \text{ (EQ. H1-1a) FOR } (P_r)/(P_c) > 0.2$$

$$(P_r)/(P_c) = (236/309) = 0.76 > 0.2$$

$$(236/309) + (8/9)(12.82/190.4) = 0.76 + 0.06 = \underline{0.82 < 1.0}$$

18" DIA. X 3/8" WALL THICKNESS (ASTM A252, GRADE 2) PIPE IS ACCEPTABLE



EXAMPLE 7.3 – SHORING WALL DESIGN

PROBLEM:

THE DESIGN BENDING MOMENT (M_{DESIGN}) FOR A SHORING WALL IS 84 kip-ft per lineal foot. SIZE THE FOLLOWING SHORING WALL MEMBERS FOR THIS DESIGN MOMENT*:

- (A) STEEL SHEET PILES
- (B) SOIL-MIX WALL PILES INSTALLED @ 4'-0" ON-CENTER

*NOTE: OTHER FACTORS NOT CONSIDERED IN THIS EXAMPLE (e.g., SHORING WALL STIFFNESS REQUIRED TO LIMIT WALL DEFLECTION, AXIAL LOAD IN SHORING WALL PILES, ETC.) MAY AFFECT THE DESIGN OF THE SHORING WALL MEMBERS.

SOLUTION:

- (A) STEEL SHEET PILES

ASSUME SHEET PILES CONFORM TO ASTM A328 ($F_b=25$ ksi)

$$S_{REQD} = \frac{12M_{DESIGN}}{F_b} = \frac{12(84)}{25} = \underline{40.3 \text{ in}^3/\text{ft}}$$

<u>ACCEPTABLE SHEET PILE SECTIONS</u>	<u>S (in³/ft)</u>
ARBED AZ26	48.4
HOESCH H2500	46.1
CASTEEL CZ148	40.9
OTHER ACCEPTABLE SHEET PILE TYPES ARE AVAILABLE	

- (B) SOIL-MIX WALL PILES INSTALLED AT 4'-0" ON-CENTER

ASSUME PILE STEEL CONFORMS TO ASTM A572, GRADE 50 ($F_b = 33$ ksi)

$$S_{REQD} = \frac{12(\text{PILE SPACING})(M_{DESIGN})}{F_b} = \frac{12(4)(84)}{33} = \underline{122.2 \text{ in}^3/\text{pile}}$$

<u>ACCEPTABLE PILE SIZES</u>	<u>S (in³/pile)</u>
W18X71	127
W21X62	127
W24X62	131
OTHER ACCEPTABLE PILE SIZES ARE AVAILABLE	



EXAMPLE 7.4 – WOOD LAGGING DESIGN

PROBLEM:

DETERMINE THE WOOD LAGGING THICKNESS REQUIRED FOR THE SHORING GEOMETRY ILLUSTRATED BELOW. ASSUME P (SHORING DESIGN LOADING) IS 1200 psf.

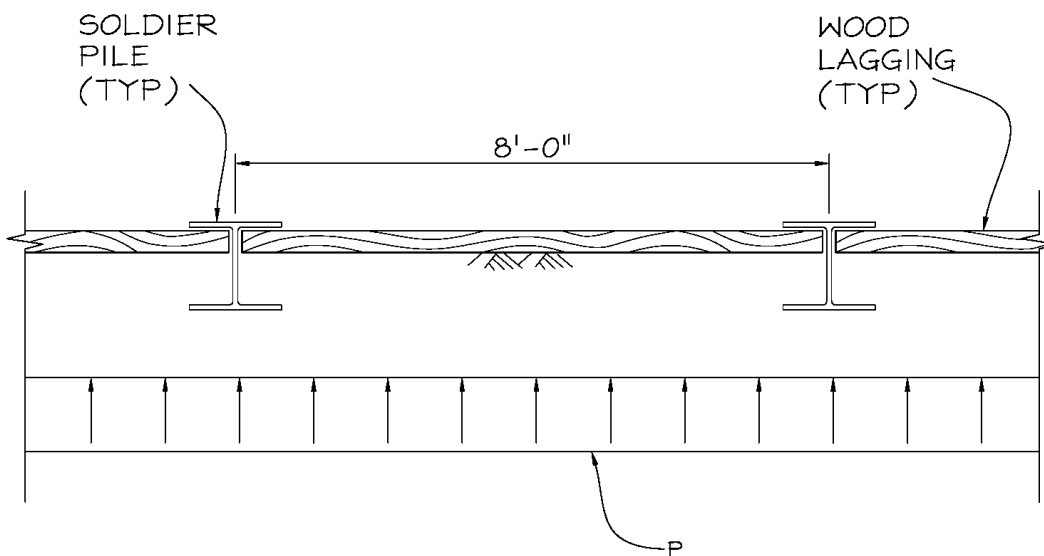



SOLUTION:

COMPUTE LAGGING DESIGN LOADING ($P_{LAGGING}$) –

$$P_{LAGGING} = 0.6P = 0.6(1200) = \underline{720 \text{ psf}}$$

COMPUTE M_{MAX} AND V_{MAX} –

$$M_{MAX} = \frac{P_{LAGGING}(\text{PILE SPACING})^2}{8} = \frac{720(8)^2}{8} = \underline{5760 \text{ lb-ft/ft}}$$

$$V_{MAX}^* < \frac{P_{LAGGING}(\text{PILE SPACING})}{2} = \frac{720(8)}{2} = \underline{2880 \text{ lb/ft}}$$

(*CONSERVATIVE, V_{MAX} CAN BE TAKEN H FROM SUPPORT)

TRY 6X, S4S (THICKNESS=5½”), DOUGLAS FIR NO.2 MATERIAL –

$$A = 5.5(12) = 66 \text{ in}^2/\text{ft}$$

$$S = \frac{12(5.5)^2}{6} = 60.5 \text{ in}^3/\text{ft}$$

CHECK BENDING AND SHEAR –

$$f_b = \frac{12M_{MAX}}{S} = \frac{12(5760)}{60.5} = \underline{1142 \text{ psi} < 1500 \text{ psi OK}}$$

$$f_v = \frac{3V_{MAX}}{2A} = \frac{3(2880)}{2(66)} = \underline{65 \text{ psi} < 140 \text{ psi OK}}$$

6X, S4S, DOUGLAS FIR NO.2 MATERIAL IS ACCEPTABLE



Appendix C – SCRRRA DESIGN EXCEPTION FORM



SCRRRA DESIGN EXCEPTION FORM

Project Name: _____ Location: _____

Project No.: _____ Contract No.: _____

Date: _____

Part 1: To be Completed by Originator

ORIGINATOR	Requested by: _____ Title: _____ Company: _____ Signature: _____ Print Name: _____	
IMPACTS	Does this Exception impact Safety and Operations? Does this Exception conflict with any CPUC/CA MUTCD regulations and requirements? Does this Exception impact economic, social or environmental issues?	<input type="checkbox"/> Yes <input type="checkbox"/> No <input type="checkbox"/> yes <input type="checkbox"/> No <input type="checkbox"/> yes <input type="checkbox"/> No
EXCEPTION INFORMATION	Does the exception affect the following? Engineering Standards <input type="checkbox"/> Yes <input type="checkbox"/> No Specifications <input type="checkbox"/> Yes <input type="checkbox"/> No Design Criteria <input type="checkbox"/> Yes <input type="checkbox"/> No Manual Section <input type="checkbox"/> Yes <input type="checkbox"/> No Description of Exception/Waiver: Rational for Exception/Waiver: Mitigation Measures:	



<p>REASON FOR REQUEST</p>	<p>Design Exception/Waiver must address the following:</p> <ul style="list-style-type: none"> • Established Design Criteria versus proposed and existing criteria • Reason the appropriate design criteria cannot be met • Justification for the proposed Criteria • Any background information which documents, support or justify the request • Any mitigation that will be provided to further support or justify the request • Safety implication of the request • The comparative cost of the full standard versus the lower design being proposed. Show what it would cost to meet the standard for which the Exception/waiver is requested • Long term effect of the reduced design as compared to the full standard
<p>ATTACHMENTS</p>	<p>The completed SCRRRA Design Exception Form and all supporting documentation (drawings, reports, and calculations) shall be submitted with all requests for exceptions. This form (at the end of this page) and all documentation attached with the request must be stamped and sealed by a Registered California Engineer.</p>

Part 2: SCRRRA approval Signatures

<p>SCRRRA APPROVALS</p>	<p>Name</p>	<p>Date</p>
		<p>Ron Mathieu, Manager, Rail Corridor C&E</p>
	<p>Naresh Patel, P.E., Manager, Civil Engineering</p>	
	<p>Dan Guerrero, Manager, C&S Engineering</p>	
	<p>Fred Jackson, Manager, System Safety</p>	
	<p>Darrell Maxey, P.E., Director, E&C</p>	